



ELECTRIC CITIES OF ALABAMA

UNITING ALABAMA'S ELECTRIC CITIES



2026 MEMBERSHIP DIRECTORY



Smart utility
solutions taking
you from now to
next.



TABLE OF CONTENTS

ASSOCIATION INFORMATION

About Electric Cities of Alabama.....	14-15
ECA Staff.....	16
2024-2026 ECA Officers and Executive Committee.....	17

ALABAMA'S ELECTRIC CITIES

Albertville.....	21
Alexander City.....	23
Andalusia.....	25
Athens.....	27
Bessemer.....	29
Brundidge.....	31
Courtland.....	33
Cullman.....	35
Decatur.....	37
Dothan.....	39
Elba.....	41
Evergreen.....	43
Fairhope.....	45
Florence.....	47
Foley/Riviera.....	49
Fort Payne.....	51
Guntersville.....	53
Hartford.....	55
Hartselle.....	57
Huntsville.....	59
LaFayette.....	61
Lanett.....	63
Luverne.....	65
Muscle Shoals.....	67
Opelika.....	69
Opp.....	71
Piedmont.....	73
Robertsdale.....	75
Russellville.....	77
Scottsboro.....	79
Sheffield.....	81
Sylacauga.....	83
Tarrant.....	85
Troy.....	87
Tuscumbia.....	89
Tuskegee.....	91



**ALTEC.
ONE SOURCE
FOR ALL
OF YOUR
EQUIPMENT
NEEDS.**

At Altec, we believe better equipment starts from the ground up. That's why we offer innovative and reliable products that exceed industry standards. Coupled with our award-winning service, Altec provides solutions to meet all your equipment needs.

SALES | SERVICE | RENTAL | SAFETY TRAINING | TOOLS & ACCESSORIES

Contact:

Jason Janoulis
Account Manager - South AL/FL Panhandle
205.789.9814
jason.janoulis@altec.com

Jeff Stevens
Account Manager - North Alabama
205.914.5046
jeff.stevens@altec.com

Cory Corcoran - Altec Supply
Account Manager - AL/FL Panhandle
601.850.4974
cory.corcoran@altec.com



altec.com
800.958.2555
sales@altec.com

33 Inverness Ctr. Pwy. Suite 110, Birmingham, AL 35242

Altec® and the Altec logo are registered trademarks of Altec Inc. in the United States and various other countries. © 2017 Altec Inc. All Rights Reserved.

TABLE OF CONTENTS

POWER PROVIDERS

Alabama Power.....	100
Constellation.....	98
Energy Southeast.....	94-95
PowerSouth Energy Cooperative.....	99
Tennessee Valley Authority.....	96-97

ASSOCIATE MEMBERS

Associate Member Information.....	104-128
Alabama 811.....	106
Alabama Municipal Insurance Corporation.....	106
Allen & Hoshall, Inc.....	107
Altec Industries, Inc.....	107
Asplundh Tree Expert, LLC.....	107
ATK Energy Group.....	108
Beneficial Electrification League.....	108
Better Safety and Training, LLC.....	109
Cahaba Energy Solutions, LLC.....	109
Cape Electrical Supply.....	109
Central Service Association.....	110
Corbitt Power & Light, LLC.....	110
Dragonfly Internet.....	111
Electric Cities of Georgia (ECG).....	111
Emerald Transformer.....	112
Fisher Arnold.....	112
GRESKO.....	113
Hubbell Power Systems.....	113
Irby Utilities.....	114
IUC - Interactive Utility Communications.....	114
Jackson Line Clearing.....	115
Jackson Thornton CPAs & Consultants.....	115
JJ Kane Auctions.....	116
JP Gaines Company.....	116
Mayer Electric Supply, Inc.....	116
Milwaukee Tool.....	117
NexGen Utility Sales.....	117
NISC (National Information Solutions Cooperative).....	118
NTS, Inc.....	118
Osiose Utilities Services, Inc.....	119
Preferred Sales Agency.....	119
Royal Engineers and Consultants, LLC.....	119
Sensus.....	120

A CENTURY OF INTEGRITY IN INFRASTRUCTURE.



From initial landowner notifications through the settlement of construction damage claims, Volkert provides a full complement of real estate and land acquisition services to energy companies.

VOLKERT



VOLKERT.COM

TABLE OF CONTENTS

ASSOCIATE MEMBERS CONTINUED

Service Electric Company.....	120
South Source Sales.....	121
Stewart Engineering, Inc.....	121
Sumter Utilities, Inc.....	121
Sunbelt Solomon.....	122
Swift Industrial Power.....	122
Tallman Equipment Company, Inc.....	123
Taylor Electric, Inc.....	123
Tennessee Valley Public Power Association (TVPPA).....	124
Terex Utilities.....	124
The Okonite Company.....	125
Thompson Engineering.....	125
TRC Companies, Inc.....	126
Utility Specialists, Inc.....	126
Volkert, Inc.....	127
Wesco.....	127
Whitehead & Associates, Inc.....	128

ALABAMA RURAL ELECTRIC ASSOCIATION

AREA Members.....	132-134
-------------------	---------

ELECTRIC CITIES OF ALABAMA

Map of Member Cities.....	138
---------------------------	-----

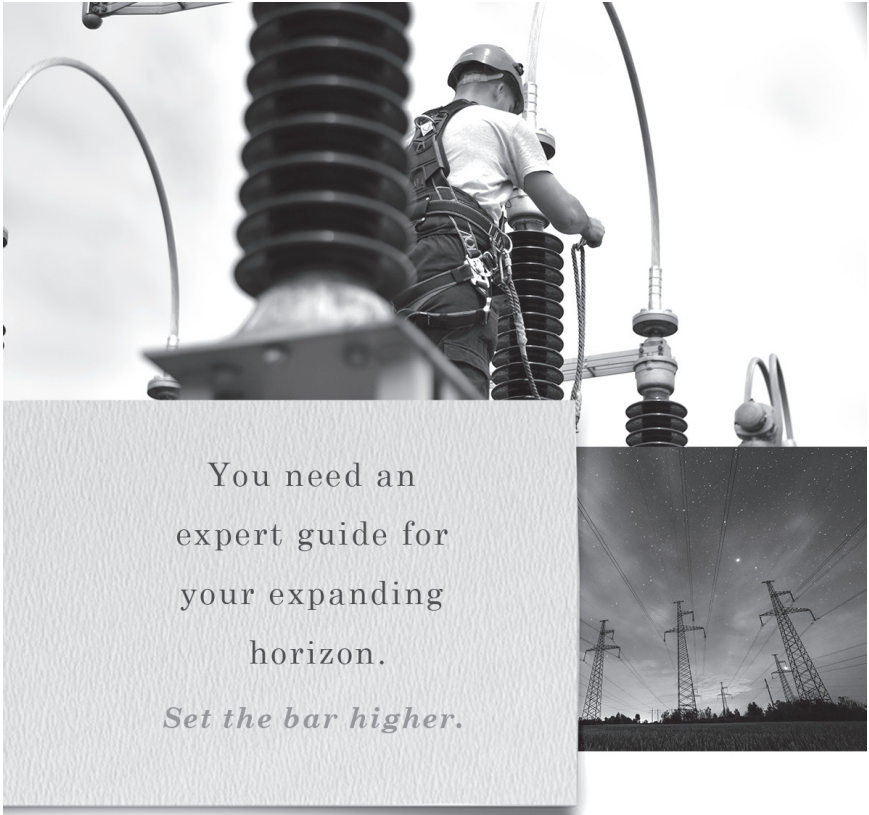

You need an
expert guide for
your expanding
horizon.

Set the bar higher.

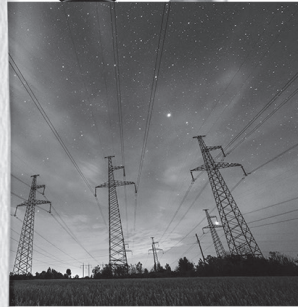

With all eyes on the bottom line, a utility can easily get lost in regulatory requirements, administrative procedures and uphill efforts. Set the bar higher. Put the 70+ years of experience of Jackson Thornton's accountants, tax experts and consultants to work for your utility.

jacksonthornton.com 334.834.7660

ELECTRIC
WATER & SEWER
GAS
TELECOMMUNICATIONS

**JACKSON
THORNTON**

Certified Public Accountants
& Consultants

INDEX OF ADVERTISERS

INDEX OF ADVERTISERS

Alabama 811.....	12
Alabama Municipal Insurance Corporation.....	18
Allen & Hoshall, Inc.....	30
Altec Industries, Inc.....	4
Asplundh Tree Expert, LLC.....	36
ATK Energy Group.....	52
Beneficial Electrification League.....	42
Better Safety and Training, LLC.....	62
Cahaba Energy Solutions, LLC.....	54
Cape Electrical Supply.....	68
Central Service Association.....	80
Corbitt Power & Light, LLC.....	20
Dragonfly Internet.....	90
Electric Cities of Georgia (ECG).....	72
Emerald Transformer.....	92
Energy Southeast.....	Back Cover
Fisher & Arnold, Inc.....	101
GRESKO.....	44
Hubbell Power Systems.....	129
Irby Utilities.....	78
IUC - Interactive Utility Communications.....	102
Jackson Line Clearing.....	88
Jackson Thornton & Co., P.C., CPA's.....	8
JJ Kane Auctions.....	66
JP Gaines Company.....	48
Mayer Electric Supply, Inc.....	46
Milwaukee Tool.....	34
NexGen Utility Sales.....	38
NISC (National Information Solutions Cooperative).....	64
NTS, Inc.....	50
Osmose Utilities Services, Inc.....	136
Preferred Sales Agency.....	137
Royal Engineers and Consultants, LLC.....	58
Sensus.....	Inside Front Cover
Service Electric Company.....	32
South Source Sales.....	60

TVPPA EDUCATION
& TRAINING
**EMPOWER
YOUR
EMPLOYEES**



TECHNICAL TRAINING

- Lineman Apprenticeship Program
- Advanced Lineworker Training
- Power Line Design & Staking
- Substation Maintenance Program
- Electrical Metering Program
- Protective Relaying Program
- Distribution System Operator
- Certified Power Technology
- Power Distribution Engineer

**BUSINESS MANAGEMENT
TRAINING**

- Certified Power Executive
- Advanced Certified Power Executive
- Certified Power Supervisor
- Certified Safety Coordinator
- Certified Utility Accountant
- Certified Utility Human Resources
- Foreman Academy
- Utility Security Professional
- Certificate of Customer Service
- Utility Purchasing & Materials Management

Get the utility-specific training your staff needs. From technical programs like our renowned Lineman Apprenticeship Program to our wide-ranging business management classes, TVPPA offers the right tools to empower your employees.

To learn more, visit tvppa.com/training or contact Caleb Hall, TVPPA Director, Education at 423.883.5000 or chall@tvppa.com today.



INDEX OF ADVERTISERS

INDEX OF ADVERTISERS

Stewart Engineering, Inc.....	135
Sumter Utilities, Inc.....	24
Sunbelt Solomon.....	76
Swift Industrial Power.....	82
Tallman Equipment Company, Inc.....	74
Taylor Electric, Inc.....	84
Tennessee Valley Public Power Association (TVPPA).....	10
Terex Utilities.....	56
The Okonite Company.....	86
Thompson Engineering.....	26
TRC Companies, Inc.....	70
Utility Specialists, Inc.....	22
Volkert, Inc.....	6
Wesco.....	28
Whitehead & Associates, Inc.....	40



**Know what's below.
811 before you dig.**

CONTACT 811 BEFORE YOU DIG



Every digging project requires contacting Alabama 811 -- even small projects like planting shrubs and trees, building a deck, installing a mailbox or fence.

Go online to submit your locate request or call 811 least two full working days prior to starting your work but not counting the day you notify Alabama 811! This process will get the buried lines of Alabama 811 member utility companies marked for free!

This complies with the requirements of Alabama's Underground Damage Prevention Law and, helps prevent undesired consequences and possible service disruptions to your neighborhood.

Safe Digging Is No Accident: Contact 811 Before You Dig.



Visit www.al811.com for more information.



ELECTRIC CITIES
OF ALABAMA

**ASSOCIATION
INFORMATION**

About

Electric Cities of Alabama

P.O. Box 1550 | Montgomery, AL 36102-1550
770 Washington Ave., Suite 164 | Montgomery, AL 36104
Phone: (334) 954-3221 | www.electriccities.org

Electric Cities of Alabama (ECA) is proud to serve approximately one million customers in 36 cities across the beautiful State of Alabama. From the Tennessee Valley region in the north to the gulf and wiregrass regions in the south, ECA's municipally owned electric utilities offer reliable and low-cost electricity.

Board of Directors

The ECA Board of Directors is composed of one representative from each participating member city. The Board of Directors establishes the policies of the association and meets quarterly.

Services Provided by ECA

State Governmental Affairs Activities

For the purpose of statewide unity of Alabama's electric cities, ECA makes every effort to achieve consensus among its member utilities and serves as the voice of Alabama's electric cities. Activities are facilitated by ECA staff by bringing representatives of member cities together with their elected officials throughout the year. These activities develop a better working relationship between electric cities and their respective legislators, as well as other elected officials.

To this end, ECA provides the following services to its members:

- State and National Governmental Affairs Activities
- Legislative and Regulatory Coordination
- Regular Legislative Updates and Legislative Alerts
- Legislative Council Development
- Annual Alabama Legislative Appreciation Reception
- Annual Legislator Recognition
- Political Action Support

- Legislative Coalition Building
- Memberships and Sponsorships
- Public Relations

National Governmental Affairs Activities

ECA works closely with the American Public Power Association's (APPA) legislative staff to support legislative efforts that impact ECA's membership. Activities include communications and contacts with the Alabama congressional delegation, urging support of Electric Cities legislative agenda within Alabama and the nation.

Washington Legislative Conference

For the purpose of federal legislation, ECA makes every effort to achieve consensus among its member utilities and serves as the voice of Alabama's electric cities. Activities are facilitated by ECA staff by bringing representatives of member cities together with Alabama's congressional delegation. These activities aid developing working relationships with electric cities and their federally elected officials.

Communications & Public Relations

Electric Cities of Alabama has developed a comprehensive program for enhancing public relations and communications of public power within Alabama. Following is a list of the various mediums we provide:

- Membership Development
- Newsletter: Electric Cities Connected
- Annual ECA Membership Directory
- News Media Contacts
- Disaster Communication Services
- Association Website: www.electriccities.org

Disaster Assistance & Coordination

ECA shall act as the statewide assistance coordinator during times of significant natural disasters such as hurricanes, tornadoes and ice storms. ECA staff will work with municipal organizations across the United States to coordinate an emergency response program.

ECA Staff

Jonathan Hand, Executive Director

Jon Hand joined ECA in 2009 as Executive Director, where he represents 36 municipally owned electric utilities across the State of Alabama. Jon's responsibilities include coordinating all federal and state governmental relations and legislative activities to mutual aid and disaster assistance for member utilities.



Donna Key, Director of Communications and Events

Donna Key joined ECA in 2017 as the Director of Communications and Events. Having worked in Association management for more than two decades, Donna has a diverse knowledge of meeting and event planning, public relations, marketing, and member relations.

2025-2026 **ECA Officers** **and Executive Committee**



Elden Chumley, Chairman

General Manager/CEO, Municipal Utilities Board of
Albertville

Phone: (256) 878-3761

Email: echumley@mub-albertville.com

Term Expires: July, 2026



Sherry Sullivan, Vice-Chairman

Mayor, Director of Operations, City of Fairhope

Phone: (251) 928-8003

Email: sherry.sullivan@fairhopeal.gov

Term Expires: July, 2026



Brian Chandler, Secretary/Treasurer

General Manager, City of Troy Utilities

Phone: (334) 566-0177

Email: brian.chandler@troyal.gov

Term Expires: July, 2026

- **Immediate Past President: Phillip Chaney**, Retired, Scottsboro Electric Power Board
- **Louis Davidson**, City Clerk, City of Lafayette
- **Matt Bernauer**, General Manager, Muscle Shoals Electric Board
- **Mitch Miller**, General Manager, Sylacauga Utilities Board
- **Jeff McDonald**, General Manager, Tuscumbia Utilities



INSURING THE FUTURE OF LOCAL GOVERNMENT

**AMIC PROUDLY SERVES MORE THAN 580
ALABAMA CITIES, TOWNS, UTILITIES AND
MUNICIPAL ASSOCIATIONS**

- MUNICIPAL INSURANCE
- SALES AND UNDERWRITING
- LOSS CONTROL
- EMPLOYMENT PRACTICES
- DEFENSIVE DRIVING SKIDCAR INSTRUCTION
- FIRE ARMS TRAINING SYSTEM
- POLICE SAFETY CONSULTING



110 NORTH RIPLEY STREET, MONTGOMERY, AL 36104
334.386-3863 | 1.866.239.AMIC



ELECTRIC CITIES
OF ALABAMA

**MEMBER
UTILITIES**

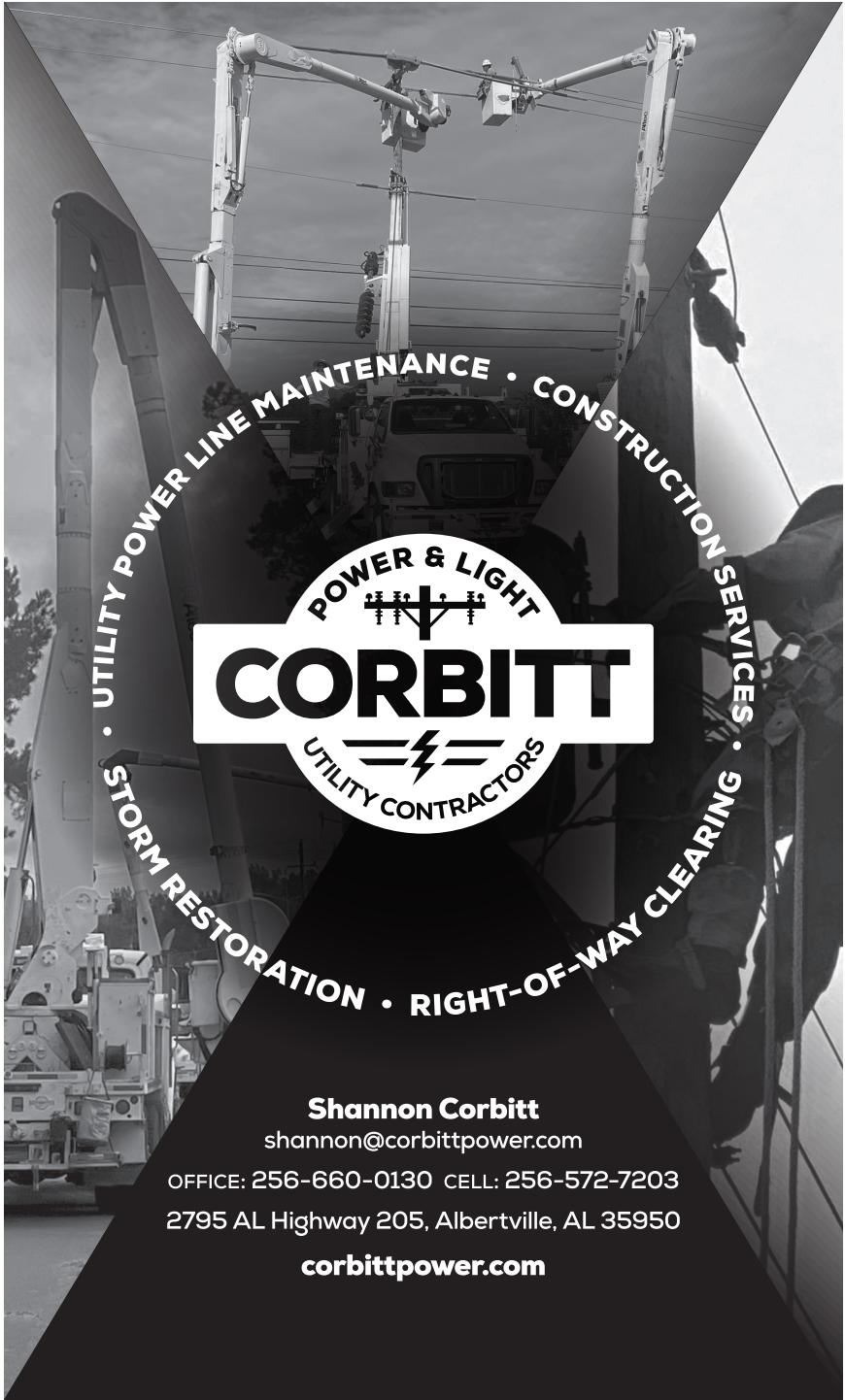

UTILITY POWER LINE MAINTENANCE • CONSTRUCTION SERVICES •
STORM RESTORATION • RIGHT-OF-WAY CLEARING

POWER & LIGHT



CORBITT



UTILITY CONTRACTORS

Shannon Corbitt

shannon@corbittpower.com

OFFICE: 256-660-0130 CELL: 256-572-7203

2795 AL Highway 205, Albertville, AL 35950

corbittpower.com

Municipal Utilities Board of Albertville

P.O. Box 130
Albertville, AL 35950-0120
210 West Main Street
Albertville, AL 35950
Phone: (256) 878-3761 ✈ Fax: (256) 878-8501
www.mub-albertville.com

Utility Manager Elden Chumley
Title..... **General Manager/CEO**
E-mail Address..... *elden@mub-albertville.com*

Legal Counsel Kenneth Wilson
Address..... P.O. Box 1203, Albertville, AL 35950
Telephone..... (256) 477-9094

Statistics

Regular Meeting of Board 3rd Tuesday of the month, 8:30 a.m.
Number of Employees 102
Utility Service Area Albertville City Limits
Total Electric Customers 10,749
Residential Customers 8,388
Commercial & Industrial Customers using less than 51 kW/month 2,110
Commercial & Industrial Customers using 51 – 4,999 kW/month 248
Gas Customers Not Applicable
Water Customers 10,764
Wastewater Customers 7,035
Total System Assets \$66,213,033
Miles of Line 343
Average Residential Usage 15,036 kWh/year
Number of Delivery Points 2
Miles of Electric Underground Not Reported
Average Load Factor 75%
Power Supplier TVA

Key Staff

Chief Financial Officer Paige Cagle
Assistant General Manager Matt George
Customer Service Manager Chris Reaves
Office Manager Donna Renfro
Electric Superintendent Heath Adams
Line Foreman Ralph Corbin
Warehouse/Purchasing Supervisor Nick Bayne
Electric Engineer Chace Walker
Billing Supervisor Corbin Battles

USI

Utility Specialists, Inc.

Manufacturers Agents Since 1957



Proudly Representing Quality Manufacturers of Power Delivery Products to Alabama's Electric Cities for since 1957.

*Please visit our website for more information on our manufacturers and products at www.utility-specialists.com
Or contact*

Joe Thornton - Territory Manager
Cell (205) 243-6911
Or our inside sales staff at
(800) 733-4837 or (205) 967-4602
Utility Specialists, Inc.
P. O. Box 43528
Birmingham, AL 35243

Alexander City Electric Department

P.O. Box 552

Alexander City, AL 35010-0552

762 Railey Road

Alexander City, AL 35010

Phone: (256) 409-2080 ✈ Fax: (256) 409-2082

www.alexandercityonline.com

SuperintendentJoe Ray

Title..... Superintendent

E-mail Address.....*joe.ray@alexandercityal.gov*

Legal Counsel..... Larkin Radney

Firm Name Larkin Radney Law Office

Address..... N. Central Avenue, Alexander City, AL 35010

Telephone..... (256) 329-8438

Fax (256) 329-0809

Statistics

Regular Meeting of Board..... City Council meeting twice each month

Number of Employees..... 14

Utility Service Area 30 Square Miles

Total Electric Customers 6,732

Residential Customers..... 4,983

Commercial & Industrial Customers using less than 51 kW/month..... 1,010

Commercial & Industrial Customers using 51 – 4,999 kW/month..... 72

Gas Customers 4,196

Water Customers 10,000

Total System Assets..... Not Reported

Miles of Line..... 160

Average Residential Usage..... 16,000 kWh/year

Number of Delivery Points 3

Miles of Electric Underground..... Not Reported

Average Load Factor..... Not Reported

Power Supplier Energy Southeast

Key Staff

Administrative Assistant Tracy Kendrick

Assistant Superintendent Bryan Lee Yates



SUMTER UTILITIES

A QUANTA SERVICES COMPANY

A full-service electric power contractor you can rely on.

Sumter Utilities builds, maintains, restores, and expands power infrastructure across the Southeast. An influential safety culture and well-trained workforce make Sumter Utilities the preferred choice for:

- Overhead Distribution
- Underground Distribution
- Transmission
- Substations
- Renewable Energy
- Emergency Restoration



WWW.SUMTER-UTILITIES.COM

803-469-8585

Utilities Board of Andalusia

P.O. Box 790

Andalusia, AL 36420-0790

Phone: (334) 222-1332 ✈ Fax: (334) 222-9058

www.cityofandalusia.com

Utility Manager Earl Johnson

Title Mayor/Chairman of Board

E-mail Address *earl.johnson@cityofandalusia.com*

Legal Counsel Mark Christensen

Firm Name Christensen Attorneys

Address P.O. Box 507, Andalusia, AL 36420

Telephone (334) 222-0303

Statistics

Regular Meeting of Board 3rd Thursday of the month

Number of Employees 52

Utility Service Area Andalusia City Limits

Total Electric Customers 4,705

Residential Customers 3,677

Commercial & Industrial Customers using less than 51 kW/month 1,023

Commercial & Industrial Customers using 51 – 4,999 kW/month 5

Gas Customers Not Applicable

Water Customers 5,053

Total System Assets \$28,992,196.00

Miles of Line 166

Average Residential Usage 16,492 kWh/year

Number of Delivery Points 4

Miles of Electric Underground 20.323

Average Load Factor Not Reported

Power Supplier PowerSouth Energy Cooperative

Key Staff

Director of Electrical Operations Tom Arnold

Asst. Electrical Operations Manager Kyle Hensley

Director of Engineering Operations David Carter

Director of Finance Operations Jennifer Curry

Utility Office Administrator Brandi Watson



Leadership on Projects Defining Skylines, Coastlines & Transportation Lines

ALABAMA | FLORIDA | GEORGIA | LOUISIANA
MISSISSIPPI | NORTH CAROLINA | TENNESSEE | TEXAS

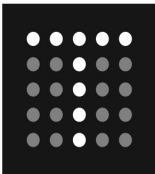

thompson
ENGINEERING

888.292.2443 | thompsonengineering.com



City of Athens Utilities

P.O. Box 1089
Athens, AL 35612-1089
1806 Wilkinson Street
Athens, AL 35612
Phone: (256) 232-1440 ✈ Fax: (256) 233-8732
www.athens-utilities.com

Utility Manager **Blair Davis**
Title..... **General Manager of Utilities**
E-mail Address..... *bdavis@athens-utilities.com*

Legal Counsel Shane Black
Firm Name Hand Arendall, LLC
Address..... 102 S. Jefferson Street, Athens, AL 35611
Telephone (256) 232-0202
Fax (256) 233-2407

Statistics

Regular Meeting of Board 2nd & 4th Monday of the month
Number of Employees 210
Utility Service Area Limestone County
Total Electric Customers 60,431
Residential Customers 52,180
Commercial & Industrial Customers using less than 51 kW/month 7,331
Commercial & Industrial Customers using 51 – 4,999 kW/month 675
Commercial & Industrial Customers using above 5,000 kW/month 5
Gas Customers 14,414
Water Customers 14,481
Wastewater Customers 10,767
Total System Assets \$228,525,751
Miles of Line 2,230
Average Residential Usage 1,281 kWh/month
Number of Delivery Points 8
Miles of Electric Underground 340
Average Load Factor 60%
Power Supplier TVA

Key Staff

Electric Services Director Hunter Allen
Construction Engineer Will Adams
General Foreman Travis McElyea
Operations Compliance Supervisor Paige Holland
Substation Operations Supervisor Nick Bearden
Customer Accounts Manager Beth Clem
Distribution Engineer Jake Hamby
Purchasing Agent Anna Leigh Peacock
Utility Controller Abigail Owen
Human Resources Director Marsha Sloss
Safety Coordinator Nick Sandlin/Justin Holland
Gas Services Director Braxton Guinn
Water Services Director Jimmy Junkin



Powering Alabama's Progress

At Wesco, we know that strong partnerships drive public power utilities forward. That's why we work side by side with utilities to modernize infrastructure, expand broadband, and integrate renewables safely and efficiently.

From electrification to automation, we help you deliver reliable, future-ready service to the communities you serve.

Let's power progress together.



Scan here
to learn more

**We build, connect, power
and protect the world.**

250 Finney Rd | Huntsville, AL 35825
256.772.5413



© 2025 Wesco International

Bessemer Electric Service

P.O. Box 1246
Bessemer, AL 35021-1246
1600 1st Avenue North
Bessemer, AL 35021
Phone: (205) 481-4333 ✈ Fax: (205) 481-4323
www.bessemerutilities.com

Utility Manager **Jerry D. Yarbrough**
Title..... **Operations Manager**
E-mail Address..... *jyarbrough@bessemerutilities.com*

Legal Counsel Shan Paden
Firm Name Paden & Paden
Address..... 1813 3rd Ave No., Ste. 200, Bessemer, AL 35020
Telephone (205) 432-0270
Fax (205) 432-0275

Statistics

Regular Meeting of Board 1st & 3rd Tuesdays of the month
Number of Employees 100
Utility Service Area Bessemer City Limits
Total Electric Customers 15,000
Residential Customers 13,000
Commercial & Industrial Customers using less than 51 kW/month 1,750
Commercial & Industrial Customers using 51 – 4,999 kW/month 250
Gas Customers Not Applicable
Water Customers 27,000
Total System Assets \$25,575,551.00
Miles of Line 180
Average Residential Usage 129,056 kWh/year
Number of Delivery Points 2
Miles of Electric Underground Not Reported
Average Load Factor 75%
Power Supplier TVA

Key Staff

Electric Operations Manager..... Jared Cartee
Principal Accountant Otis Smith
Business Office Supervisor Elita Witherspoon
Administrative Supervisor..... Chiquita Jordan



Allen & Hoshall

engineers-architects-surveyors

Substation Design

**Overhead & Underground Distribution
& Transmission Design**

**System Planning
& Power Quality Studies**

**Oil Spill Containment
& Countermeasure Plans**

System Mapping, AM/FM/GIS

**SCADA Feasibility
& Implementation**

Standby/Peak Generation

Telecommunication Design

Design/Build Projects

www.allenhoshall.com

City of Brundidge Electric Department

P.O. Box 638

Brundidge, AL 36010-0638

Phone: (334) 735-2321 ✈ Fax: (334) 735-5180

www.brundidge.org

Utility Manager **Willie Wright**
Title **City Manager**
E-mail Address *willie.wright@troycable.net*

Legal Counsel Richard Calhoun
Firm Name Calhoun Faulk, LLC
Address P.O. Box 489, Troy, AL 36081
Telephone (334) 566-7200

Statistics

Regular Meeting of Board 1st & 3rd Tuesday of the month - City Council at 6:00 p.m.
Number of Employees 4
Utility Service Area Brundidge City Limits
Total Electric Customers 1,241
Residential Customers 1,003
Commercial & Industrial Customers using less than 51 kW/month 223
Commercial & Industrial Customers using 51 – 4,999 kW/month 15
Gas Customers SE Alabama Gas Dist.
Water Customers 895
Wastewater Customers 775
Total System Assets Utility Plant Only: \$5,914,251.62
Miles of Line 68
Average Residential Usage 10,490 kWh/year
Number of Delivery Points 3
Miles of Electric Underground Less than 2 miles
Average Load Factor 60.86%
Power Supplier PowerSouth Energy Cooperative

Key Staff

Mayor Isabell Boyd



A QUANTA SERVICES COMPANY

**SERVICE ELECTRIC
BUILDS, MAINTAINS,
AND REPAIRS THE
INFRASTRUCTURE THAT
POWERS THE NATION.**

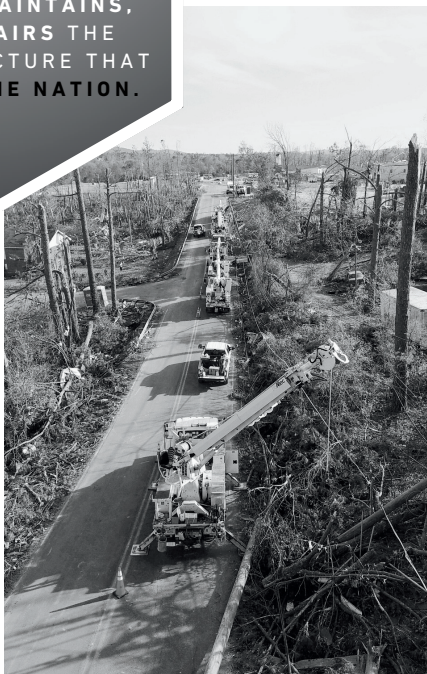

WWW.SERVICEELECTRICCO.COM | 423.265.3161 | INFO@SERVICEELECTRICCO.COM

Courtland Electric Department

P.O. Box 160
Courtland, AL 35618-0160
361 College Street
Courtland, AL 35618
Phone: (256) 637-2707 ✈ Fax: (256) 637-9336

Utility Manager **Joe Johnson**
Title **Superintendent**
E-mail Address *ricket@townofcourtland.org*

Legal Counsel **Tim Littrell**
Address 757 Lawrence Street, Moulton, AL 35650
Telephone (256) 974-1936
Fax (256) 974-3593

Statistics

Regular Meeting of Board 1st & 3rd Mondays of the month
Number of Employees 3
Utility Service Area Town Limits of Courtland & jurisdiction
Total Electric Customers 880
Residential Customers 689
Commercial & Industrial Customers using less than 51 kW/month 200
Commercial & Industrial Customers using 51 – 4,999 kW/month 17
Gas Customers Not Applicable
Water Customers 894
Total System Assets \$1,326,589.00
Miles of Line 32
Average Residential Usage 990 kWh/month
Number of Delivery Points 1
Miles of Electric Underground 0
Average Load Factor 53%
Power Supplier TVA

Key Staff

Mayor **Linda Peebles**
City Clerk **Vickie Jackson**

Parker Thelen
Territory Manager – Power Utility
Mobile: (470) 717-2250
parker.thelen@milwaukeetool.com



Nothing but **HEAVY DUTY**®.

LINEMANS



DEDICATED TO THE POWER UTILITY INDUSTRY

From the power plant, through transmission and distribution, it is MILWAUKEE's goal to improve reliability and productivity for the Lineman by offering solutions that help increase confidence while on the job. MILWAUKEE® delivers unprecedented innovation for the Power Utility industry through a wide range of power tools, cordless crimpers and cutters, high output lighting, hand tools and accessories.

**LEARN
MORE**



or visit <https://qr.mke.tt/2m2xa>



Cullman Power Board

P.O. Box 927
Cullman, AL 35056-0927
106 2nd Avenue NE
Cullman, AL 35055
Phone: (256) 734-2343 ✈ Fax: (256) 775-2534
www.cullmanpowerboard.com

Utility Manager **Allison Bright**
Title..... **Chief Executive Officer**
E-mail Address..... *abright@cullmanpowerboard.com*

Legal Counsel Thomas A. Smith, Jr.
Firm Name Smith & Smith
Address..... P.O. Box 398, Cullman, AL 35056-0398
Telephone (256) 734-4721
Fax (256) 734-4774

Statistics

Regular Meeting of Board The Tuesday after the fourth Monday of the month
Number of Employees 33
Utility Service Area Cullman City Limits
Total Electric Customers 9,009
Residential Customers 7,065
Commercial & Industrial Customers using less than 51 kW/month 1,666
Commercial & Industrial Customers using 51 – 4,999 kW/month 278
Total System Assets \$54,299,857
Miles of Line 259
Average Residential Usage 1,042 kWh/month
Number of Delivery Points 4
Miles of Electric Underground Unknown
Average Load Factor 65%
Power Supplier TVA

Key Staff

Operations Superintendent Wyatt Pettus
Accounting and Finance Manager/Office Manager Chris McDonald
Customer Service Supervisor Ken Brown
Engineering and Operations Manager Scott Whitfield
Assistant Engineering and Operations Manager Jon Helton



OUR ONE ASPLUNDH APPROACH DELIVERS TO OUR CLIENTS, PARTNERS AND COMMUNITIES, THE BEST EQUIPMENT, SERVICES AND RESOURCES THROUGH A SINGLE POINT OF CONTACT ACROSS OUR FULL SUITE OF VEGETATION, ENGINEERING AND UTILITY INFRASTRUCTURE SERVICES.

AS ONE ASPLUNDH WE CAN SCALE OUR RESOURCES TO CREATE MORE INNOVATIVE SOLUTIONS TO MEET THE DIVERSE NEEDS OF TODAY'S UTILITIES. BRINGING TOGETHER THE BEST PEOPLE, PROCESSES, EQUIPMENT AND KNOWLEDGE RESULTS IN A FUTURE THAT IS MORE CLIMATE READY, RESILIENT AND SUSTAINABLE FOR EVERYONE.

ASPLUNDH

ASPLUNDH.COM 1.800.248.TREE



Decatur Utilities

P.O. Box 2232
Decatur, AL 35609-2232
1002 Central Parkway SW
Decatur, AL 35609
Phone: (256) 552-1400 ✈ Fax: (256) 552-1412
www.decaturutilities.com

Utility Manager **Ray Hardin**
Title..... **General Manager**
E-mail Address..... *rbhardin@decaturutilities.com*

Legal Counsel David Langston
Firm Name Harris, Caddell & Shanks
Address..... P.O. Box 2688, Decatur, AL 35602
Telephone (256) 340-8000

Statistics

Regular Meeting of Board..... 3rd Thursday of the month
Number of Employees..... 178
Utility Service Area Decatur City Limits
Total Electric Customers 26,966
Residential Customers 22,938
Commercial & Industrial Customers using less than 51 kW/month..... 3,519
Commercial & Industrial Customers using 51 – 4,999 kW/month..... 509
Gas Customers 13,469
Water Customers 26,231
Wastewater Customers 21,361
Total System Assets \$624,515,140
Miles of Line..... 597
Average Residential Usage 1,175 kWh/month
Number of Delivery Points 3
Miles of Electric Underground..... 59
Average Load Factor 65%
Power Supplier TVA

Key Staff

Executive Assistant..... Rebecca Sheets
Business Manager and CFO Lisa Terry
Director-Customer & Employee Relations..... Paul Nosal
Operations Manager Gary Borden
Electric Manager Glenn Boyles



Energize Your Future with Us.

NexGen Utility Sales connects utilities and energy leaders with proven partners and leading OEMs - delivering engineered solutions for reliability, resiliency, and modernization.

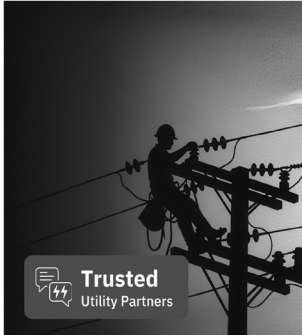

Integrated Power Solutions for Every Challenge

NexGen works with industry-leading partners to deliver custom-engineered solutions for utilities, co-ops, and municipalities.

- ✓ Grid resiliency & emergency power
- ✓ Mobile & permanent energy storage
- ✓ Custom microgrids & DER integration
- ✓ Substation and T&D equipment
- ✓ Real-time monitoring & controls



Resiliency & Energy Storage

Mobile BESS, utility-scale storage, and backup power solutions for outages, peak shaving, and emergency response.



Microgrids & DER Integration

PowerSecure microgrids, generators, solar, and hybrid systems engineered for performance and reliability.



Grid & Substation Solutions

Transformers, switchgear, structures, monitoring, cooling systems, and more - sourced through NexGen's trusted OEM network.

Dothan Utilities

P.O. Box 2128
Dothan, AL 36302-2128
200 Kilgore Drive
Dothan, AL 36301-4920
Phone: (334) 615-3300 ✈ Fax: (334) 615-3309
www.dothan.org

Utility Manager **Angie Akos, P.E.**
Title..... **Utilities Director**
E-mail Address..... *ajakos@dothan.org*

Legal Counsel..... Kevan Kelly
Firm Name City of Dothan
Address..... P.O. Box 2128, Dothan, AL 36302-2128
Telephone..... (334) 615-3130
Fax (334) 615-3139

Statistics

Regular Meeting of Board..... City Commission: 1st & 3rd Tuesday at 10:00 a.m.
Number of Employees for all of DU 182
Utility Service Area 80 square miles
Total Electric Customers 32,398
Residential Customers 26,938
Commercial & Industrial Customers using less than 121 kW/month..... 5,114
Commercial & Industrial Customers using 121 – 1,999 kW/month..... 156
Commercial & Industrial Customers using more than 1,200 kW/month..... 7
Gas Customers Southeast Gas
Water Customers 33,445
Wastewater Customers 30,133
Total Electric System Assets..... \$134,556,221.02
Miles of Line..... 1,432
Average Residential Usage 15,000 kWh/year
Number of Delivery Points 1
Miles of Electric Underground (Primary 222; Secondary 278)..... 500
Average Load Factor 60%
Power Supplier Energy Southeast & SEPA

Key Staff

Assistant Director-Electric Operations..... Micah Peckham, P.E.
Assistant Director-Water Operations..... Lindsay McDonald, P.E.
Electrical Engineering Manager..... Michael Mitchell, P.E.
Utility Collections Manager Morgan Rodriguez
Logistics and Operations Manager Jessi Snell
General Line and Service Supervisor..... Lance Littlefield
Substation Supervisor..... Jarred Wofford



Electric Utility Transmission & Distribution

Acuity Brands Lighting	Outdoor lighting including roadway, area, flood, decorative, and controls
Champion Fiber Glass	Fiberglass electrical conduit and accessories
Classic Connectors	Mechanical and electrical shunts, electrical connectors
Engel Coolers	High performance coolers, soft coolers, AC/DC fridge/freezers
Erico / nVent	
<i>Cadweld</i> ®	Exothermic grounding connectors
<i>Eritech</i> ®	Ground rods and accessories, lightning protection systems
<i>Critec</i> ®	Lightning and surge protection products and systems
Grid Graphics	Labels, signs, tags, markers
Highline / Old Castle	Transformer Pads, vaults, pedestals, fiberglass, and polycrrete
Lindsay Precast	Light pole bases, electric manhole/utility vaults, transformer vaults, and pads
Maclean Power Systems	Pole line hardware, connectors, insulators, and protection products
Pennsylvania Transformer	Power Transformers
Penta Electric Safety Products	Hot-Sticks, voltage detectors, insulated jumpers, insulated tools
Penn Union Corporation	Electrical connectors
Power Delivery Products	Fault indicators
Rotblock	Wood pole ground-line protection
Sabre Tubular Structures	Steel structures for transmission, distribution, and substation
SensorLink	High voltage meters and recorders
Southern Pipe, Inc.	PVC conduit
Southwire	Overhead and underground transmission and distribution cable
Spartan Composite	Lightweight, interlocking mats for site access, equipment protection
Ubicquia	Intelligent network lighting controls using LTE technology
Wye Delta	Safety sunglasses and eye protection
Whitlow Electric	Substation and miscellaneous steel fabrication

Outside Sales:

Peyton Whitehead (South AL) Mobile: 404.316.0920, Email: Peyton@WhiteheadAssoc.com

John Shelfer (Generation) Mobile: 205.612.7904, Email: John@WhiteheadAssoc.com

Ben Garrett (North AL) Mobile: 205.767.7629, Email Ben@WhiteheadAssoc.com

Hammond Parsons Mobile: 334.544.9054, Email: Hammond@WhiteheadAssoc.com

LINE CARD



City of Elba

200 Buford Street

Elba, AL 36323

Phone: (334) 897-2333 ✈ Fax: (334) 897-3337

www.elbaal.gov

Utility Manager **Tim Johnson**

Title **Mayor/Superintendent**

E-mail Address *tjohnson@elbaal.gov*

Legal Counsel Carmen Howell

Statistics

Regular Meeting of Board 4th Monday of the month
Number of Employees 16
Utility Service Area Elba City Limits
Total Electric Customers 1496
Residential Customers 1171
Commercial & Industrial Customers using less than 51 kW/month 314
Commercial & Industrial Customers using 51 – 4,999 kW/month 19
Gas Customers SE Alabama Gas Dist.
Water Customers 1,745
Total System Assets \$5,258,000.00
Miles of Line 85
Average Residential Usage 18,766 kWh/year
Number of Delivery Points 2
Miles of Electric Underground 10
Average Load Factor 93%
Power Supplier PowerSouth Energy Cooperative

Key Staff

Supervisor Brian Lasiter
City Clerk/Personnel Director Michael Bryant



**BENEFICIAL
ELECTRIFICATION
LEAGUE**

BEL Helps Utilities Unlock Federal Funding

Through a grant from the Appalachian Regional Commission (ARC), the Beneficial Electrification League (BEL) provides no-cost assistance to municipal utilities and cooperatives in Appalachian counties in Alabama to apply for electric infrastructure funding to support economic development.

Email BEL to see if we can help your utility:
info@BE-League.org

BE-League.org

City of Evergreen Electric Department

P.O. Box 229

Evergreen, AL 36401

Phone: (251) 578-1574 ✈ Fax: (251) 578-1526

www.evergreenal.org

Utility Manager **Chad Moore**
Title **Electrical Superintendent**
E-mail Address *cmoore@evergreenal.gov*

Legal Counsel Charlie Anderson
Firm Name Anderson, Williams, & Farrow, L.L.C
Address 7515 Halcyon Pointe Drive Montgomery, AL 36117
Telephone (334) 272-9880
Fax (334) 272-2551

Statistics

Regular Meeting of Board City Council Meeting 1st & 3rd Tuesdays of the month
 Number of Employees 8
 Utility Service Area Evergreen City Limits
 Total Electric Customers 1,815
 Residential Customers 1,438
 Commercial & Industrial Customers using less than 51 kW/month Not Reported
 Commercial & Industrial Customers using 51 – 4,999 kW/month 346
 Water Customers 1,632
 Wastewater Customers 1,343
 Total System Assets \$3,900,000
 Miles of Line 66
 Average Residential Usage 21,000 kWh/year
 Number of Delivery Points 2
 Miles of Electric Underground Not Reported
 Average Load Factor 61%
 Power Supplier Alabama Power



Because Your Work Never Stops, We're Always Here

Gresco has helped utilities power their communities for over 65 years. Whenever you need us, we are here to keep you moving forward with reliable solutions, expertise and support.

- **Vast Inventory:** One-stop shop with over 2,000 brands of power, safety and utility products—ready to ship
- **Full-Service Solutions:** Engineering, training and support tailored to enhance your efficiency and uptime
- **Strategic Locations:** Seven Southeast warehouses, so you'll always have a trusted partner close by

Supporting Your Success In:

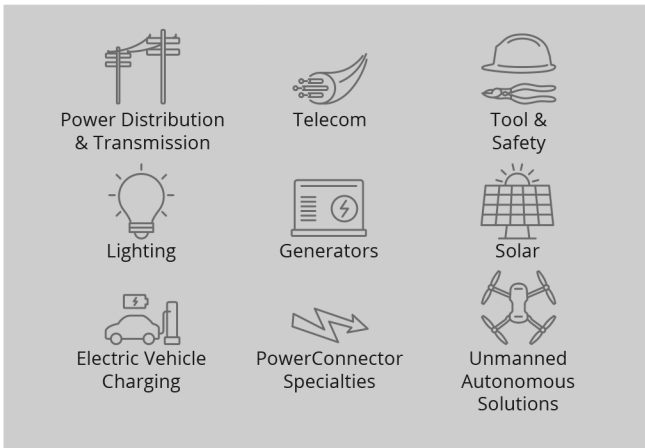

More Than a Supplier—A Partner You
Can Trust to Help Carry the Load

888.766.0621
gresco.com

Fairhope Public Utilities

P.O. Box 429
Fairhope, AL 36533
555 South Section Street
Fairhope, AL 36532
Phone: (251) 928-8003 ✈ Fax: (251) 990-0156
www.fairhopeal.gov

Utility Manager **Sherry Sullivan**
Title..... **Mayor, Director of Operations**
E-mail Address.....*sherry.sullivan@fairhopeal.gov*

Legal Counsel Marcus McDowell
Firm Name Wilkins, Bankester, Biles & Wayne, P.A.
Address..... 221 Fairhope Avenue, Fairhope, AL 36532
Telephone (251) 928-1915
Fax (251) 928-1967

Statistics

Regular Meeting of Board 2nd & 4th Monday of each month - City Council
Number of Employees 34 (Electric Department)
Utility Service Area Fairhope City Limits
Total Electric Customers 7,488
Residential Customers 6,260
Commercial & Industrial Customers using less than 51 kW/month 973
Commercial & Industrial Customers using 51 – 4,999 kW/month 110
Gas Customers 15,190
Water Customers 23,449
Total System Assets \$99,240,705
Miles of Line 90
Average Residential Usage 13,500 kWh/year
Number of Delivery Points 1
Miles of Electric Underground 20
Average Load Factor 65%
Power Supplier Energy Southeast

Key Staff

Electric Superintendent Ben Patterson

MAYER

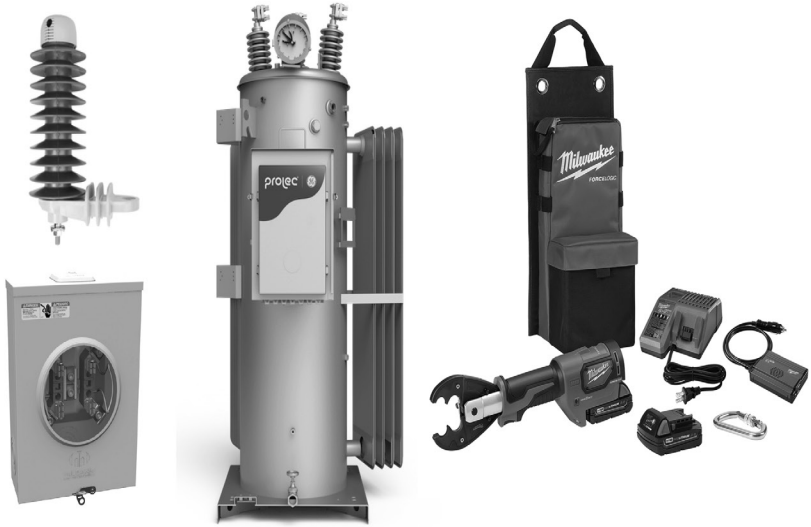

UTILITIES TRUST US

1390 Columbia Highway
Dothan, AL 36301

(334) 792-2111

Mon-Fri 7am - 4pm

Bryan Riddle (Outside Sales)
briddle@mayerelectric.com

Chad Daughtry (Inside Sales)
cdaughtry@mayerelectric.com

Coty Taylor (Inside Sales)
coty.taylor@mayerelectric.com

mayerelectric.com

Florence Electricity Department

P.O. Box 877

Florence, AL 35631

502 E Dr Hicks Blvd

Florence, AL 35630

Phone: (256) 740-6044 ✈ Fax: (256) 760-6442

www.florenceal.org

Electricity Department Manager..... Mary McDuffa, P.E.

Title..... Electricity Department Manager

E-mail Address..... mmcduffa@florenceal.org

Legal Counsel..... William T. Musgrove, III

Firm Name City Attorney

Address..... P.O. Box 98; Florence, AL 35631-0098

Telephone..... (256) 740-6040

Fax..... (256) 740-4145

Statistics

Regular Meeting of Board..... Mayor & City Council: 1st & 3rd Tuesday each month

Number of Employees..... 189

Utility Service Area Lauderdale County - 750 sq. miles

Total Electric Customers 52,253

Residential Customers..... 41,725

Commercial & Industrial Customers using less than 51 kW/month..... 9300

Commercial & Industrial Customers using 51 – 4,999 kW/month..... 745

Total System Assets..... \$163,958,895

Miles of Line..... 2667

Average Residential Usage kWh/year 14,871

Number of Delivery Points 6

Miles of Electric Underground..... 197

Average Load Factor..... 51%

Power Supplier..... TVA

Key Staff

Executive Assistant to the Manager..... Lou Pettus

Director of Engineering/Operations Allen Caddell

Director of Safety & Facilities..... Kenny Smith

Underground Electric Operations Brian Tipper

Overhead Electric Operations..... Wade Wood

Controller of Utilities..... Mark Lovejoy

Chief Accountant..... Shayla Alexander

Purchasing/Public Grants Administrator Leigh Anne Kidd

Warehouse Stores Supervisor Doug Jackson

General Foreman Line Clearance Dustin Mason

Fleet Maintenance Supervisor Darrell Pickle

Customer Service Manager..... Sandie Freedom



TOOL PROVIDER FOR THE UTILITY INDUSTRY



Patrick Martin, Operations Manager
404.444.2363
pmartin@jpgainesco.com



Steven Minton, SE Regional Sales Manager
470.328.2439
sminton@jpgainesco.com

2258 BROCKETT ROAD
TUCKER, GA 30084



404.444.2363

The Utilities Board of the City of Foley (doing business as) Riviera Utilities

413 E. Laurel Avenue

Foley, AL 36535

Phone: (251) 943-5001 ✈ Fax: (251) 943-5275

www.rivierautilities.com

Interim President and CEO Brian Skelton

E-mail Address.....*bskelton@rivierautilities.com*

Legal Counsel.....Casey Pipes

Firm NameHelmsing, Leach, Herlong, Newman & Rouse

Address.....P.O. Box 2767, Mobile, AL 36652

Telephone.....(251) 432-5521

Fax.....(251) 432-0633

Statistics

Regular Meeting of Board.....4th Tuesday of the month

Number of Employees.....281

Utility Service Area.....200 Square Miles

Total Electric Customers.....59,489

Residential Customers.....51,994

Commercial & Industrial Customers using less than 51 kW/month.....7388

Commercial & Industrial Customers using 51 – 4,999 kW/month.....459

Gas Customers.....7,875

Water Customers.....18,989

Wastewater Customers.....8,943

Total System Assets.....\$577,448,456.09

Miles of Line.....1,385

Average Residential Usage.....1,230 kWh/month

Number of Delivery Points.....8

Miles of Electric Underground.....567

Average Load Factor.....57 %

Power Supplier.....AMEA

Key Staff

Executive Assistant to CEO.....Jody Worsley

Chief Administrative Officer.....James Wallace

Chief Operating Officer.....Tony Schachle

Chief Financial Officer.....Michele Boling

IT Manager.....Wesley McKenzie

**We no longer classify residential property as commercial if the property is in the property owner or builders name.*



ERMCO and ECI Components

Single Phase and Three Phase Oil Filled Distribution Transformers, Fuses, Bushings, Arrestors

Siemens Energy

Regulators, Regulator service and replacement parts, High Voltage Arresters (Distribution and Substation Class)

Siemens Industry

MV SDV Circuit Breakers, MV Reclosers SDR and Compact Module Recloser (CMR), MV Packages, LV Motor Control Centers, MV Gas Insulated Switchgear, Fusesaver, Bridges Disconnect Switches, MV Air Insulated Switchgear, DG Automation systems and products, String & Central Inverters, DG Software, Service and Replacement parts for MV Products

Prysmian Group

Primary URD Cable (TRXLP AND EPR), ACSR, AAAC, AAC, 600 Volt Cable (Service Drop and Underground), Control Cable, Fiber Optic Cable (ADSS, OPGW), Cable Accessories

Richards Manufacturing

Network Protectors & Related Equipment, Copper and Aluminum Buss Work, 200 Amp Loadbreak, 600/900 A Deadbreak, Connectors

Mastro Graphics

Pole Numbering, Signs, Tags, and Stickers

Power Design Inc.

Fiberglass 15 KV, 25 KV And 35 KV Sectionalizing Cabinets, Pad Mounted Switchgear, Primary Metering Enclosures and Fiberglass Buildings

Southern Grounding

Ground Rods and Ground Rod Accessories

UTILCO

Electrical Connectors, Taps, Splices, Grounding Connectors, Battery Operated Tools

Columbia Manufacturing

Rotomolded linear low-density polyethylene secondary pedestals for the electric utility industry

PBC Precast

Concrete transformer pads, box pads, lighting pole bases and custom concrete precast solutions

NTSTek

Cisco Partner, Axis Communications, Palo Alto Networks, and VEEAM- 100% focused on Electric Utilities with dedicated Account Manager; CCIE Routing/Switch and Security on staff.

Phisterer

Shear Bolt Connectors for Underground Applications

PLEASE CONTACT:

Matt Bailey, Sales | (601) 594-5656 | mab Bailey@ntsrep.com

JR Bond, Sales | (205) 789-8921 | jbond@ntsrep.com

Fort Payne Improvement Authority

P.O. Box 680617
Fort Payne, AL 35968-0617
406 3rd Street SE
Fort Payne, AL 35967
Phone: (256) 845-0671 ✈ Fax: (256) 845-6688
www.FPIA.com

Utility Manager **Mike Shirey**
Title..... **General Manager**
E-mail Address..... *msbirey@fpia.com*

Legal Counsel Stephen Bussman
Address..... 212 Alabama Avenue SW, Fort Payne, AL 35967
Telephone..... (256) 845-7900
Fax (256) 845-4696

Statistics

Regular Meeting of Board..... 2nd Tuesday of the month
Number of Employees..... 30
Utility Service Area Fort Payne City Limits and surrounding areas of DeKalb County
Total Electric Customers 9,051
Residential Customers 6,967
Commercial & Industrial Customers using less than 51 kW/month..... 1,809
Commercial & Industrial Customers using 51 – 4,999 kW/month..... 235
Total System Assets \$55,825,566
Miles of Line..... 429
Average Residential Usage 1,154 kWh/month
Number of Delivery Points 4
Miles of Electric Underground..... 32
Average Load Factor 64.9%
Power Supplier TVA

Key Staff

Line Supervisor Lance Woods
Chief Accountant Aaron Benefield
Engineering..... Wes Scott
Substation Supervisor..... Jonathan Henderson
Purchasing Officer Wyatt Evans
Customer Service and Billing..... Debbie Rice
Human Resources..... Brandi Bell



SEE THE DIFFERENCE

OneSource Restoration is here for you to provide professional damage assessors, linemen, wire down watchers, logistic support, vegetation crews, and other storm restoration services.

YOUR STORM RESPONSE PARTNER

- ⚡ **Distribution Line Construction & Maintenance**
- ⚡ **System Hardening & Reliability Upgrades**
- ⚡ **Project & Field Management**
- ⚡ **Vegetation & Management Crews**
- ⚡ **Quality Assurance & Inspections**
- ⚡ **Damage Assessment & Restoration Support**
- ⚡ **Resource Coordination & Logistics Support**
- ⚡ **Safety Oversight & Workforce Development**



(855) 416-6772



WWW.ATKENERGYGROUP.COM

WWW.OSR.ENERGY



ATK Energy Group was built to redefine the utility industry through an unwavering commitment to safety, productivity, and integrity. With decades of combined experience across all ATK companies, we deliver exceptional service and innovative solutions for our partners in a rapidly evolving industry.

Guntersville Electric Board

701 Blount Avenue
P.O. Box 45
Guntersville, AL 35976-1165
Phone: (256) 582-5691 ✈ Fax: (256) 582-5929
www.guntersvilleelectric.com

Utility Manager **Jason Kirkland**
Title..... **General Manager**
E-mail Address..... *jkirkland@ebofg.com*

Legal Counsel George Barnett
Address..... 431 Gunter Avenue, Guntersville, AL 35976
Telephone (256) 582-0133

Statistics

Regular Meeting of Board last Friday of the month
Number of Employees 36
Utility Service Area Guntersville City Limits and part of Marshall County
Total Electric Customers 6,940
Residential Customers 4,868
Commercial & Industrial Customers using less than 51 kW/month 1,865
Commercial & Industrial Customers using 51 – 4,999 kW/month 163
Commercial & Industrial Customers using greater than 5,000 kW/month 1
Total System Assets \$38,764,611.50
Miles of Line 307
Average Residential Usage 1,214kWh/month
Number of Delivery Points 1
Miles of Electric Underground 30
Average Load Factor 65%
Power Supplier TVA

Key Staff

Director of System Operations and Technical Services Nathan Matthews
Office Manager/Key Accounts Sonata Howell
Chief Financial Officer Cara Dixon
Internal Auditor/Corporate Compliance Willette Lynch
Metering & Billing Supervisor Cleo Looney, Jr.
Supervisor of Distribution and Maintenance Bruce Brown
Supervisor of Transportation Curtis Perry
Supervisor of Customer Services Warren Jones
Coordinator of Customer Services and Community Relations Shenequah DeBerry



Cahaba Energy Solutions



Innovative Solutions. Backed by Experience.

Cahaba Energy Solutions is woman-owned, employee-focused, and backed by 350+ years of combined expertise in custom power and fiber services.



Power Line Services

- Construction Inspections
- Crew Coordination
- Project Management
- Job Estimating & Closeouts
- Designated Qualified Observers
- Line Crew Safety Audits
- Oil Testing for Pad-Mounted Switchgear



Storm Response

- Evaluation, Damage Assessment, Troubleshooting
- Crew Leaders
- Crew Onboarding for Off-System Contractors
- Feeder Restoration Coordinators (FRCs)
- Drone Inspections



Fiber Services

- Construction Inspections
- Crew Coordination
- Physical & Optical Fiber Design
- Placing & Splicing Crews
- Troubleshooting & Repair
- Restoration
- Project Management
- Job Estimating & Closeouts

cahabaenergysolutions.com · (205) 259-6469 · admin@cahabaenergysolutions.com

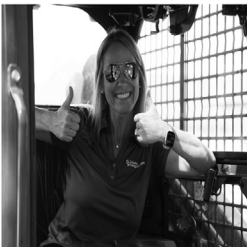
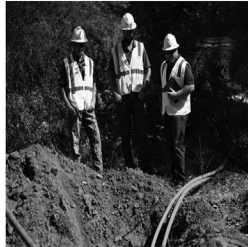

City of Hartford

203 W. Main Street
Hartford, AL 36344
Phone: (334) 588-2245 ✈ Fax: (334) 588-3826
www.cityofhartfordal.org

Utility Manager **Patrick Fondren**
Title **Superintendent**
E-mail Address *utilities@cityofhartfordal.org*

Legal Counsel Bart Boothe
Address 206 N Lena St Dothan, AL 36303
Telephone (334) 897-3413

Statistics

Regular Meeting of Board 1st & 3rd Mondays of the month
Number of Employees 6
Utility Service Area Hartford City Limits
Total Electric Customers 1,405
Residential Customers 1,200
Commercial & Industrial Customers using less than 51 kW/month 150
Commercial & Industrial Customers using 51 – 4,999 kW/month 2
Gas Customers Not Applicable
Water Customers 1,450
Total System Assets Not Reported
Miles of Line 34
Average Residential Usage 16,271 kWh/year
Number of Delivery Points 2
Miles of Electric Underground 0.6
Average Load Factor 60%
Power Supplier Constellation

Key Staff

Mayor Jeanna Brannon
City Clerk/Treasurer Kim Flowers
Utilities Clerk Khris Ballard



TEREX®

**EQUIPMENT
SERVICE
PARTS**



**For more information on
Terex Utilities equipment, auger tooling,
service or parts -
Call 1.844.TEREX.4U
or visit online at www.terex.com/utilities**



TEREX | SERVICES

Equipment Sales Contact:
Griffin Petranka
Griffin.Petranka@terex.com
470.580.9712

**4120 Lewisburg Road
Birmingham, AL 35207
205.841.6411**

BUILT. DIFFERENT.

Terex is a registered trademark of Terex Corporation in the USA and many other countries. ©2025 Terex Corporation.

Hartselle Utilities

P.O. Box 448
Hartselle, AL 35640-0448
1010 Sparkman Street NW
Hartselle, AL 35640
Phone: (256) 773-3340 ✈ Fax: (256) 773-3384
www.hartselleutilities.org

Utility Manager **Ty Chancellor**
Title..... **General Manager**
E-mail Address..... *tchancellor@hartselleutilities.org*

Legal Counsel David Langston
Firm Name Harris, Caddell & Shanks
Address..... P.O. Box 2688, Decatur, AL 35640
Telephone (256) 340-8048
Fax (256) 340-8040

Statistics

Regular Meeting of Board 1st Monday of the month
Number of Employees 57
Utility Service Area Hartselle City Limits
Total Electric Customers 5,793
Residential Customers 4,654
Commercial & Industrial Customers using less than 51 kW/month 1,035
Commercial & Industrial Customers using 51 – 4,999 kW/month 103
Gas Customers 4,690
Water Customers 7,424
Wastewater Customers 5,110
Total System Assets \$77,621,784.00
Miles of Line 199
Average Residential Usage 13,809 kWh/year
Number of Delivery Points 1
Miles of Electric Underground 41
Average Load Factor 59.0%
Power Supplier TVA

Key Staff

Finance & Accounting Manager Mark Villarino
HR Manager/Board Secretary Carol Kirby
Customer Service Manager Greg Sandlin
Facilities & Purchasing Manager Sherry Chenault
Electric Superintendent Bryan Hall
Wastewater Treatment Plant Manager Wade Sims
Engineering Services Manager Dustin Chambers
Field Operations Superintendent Cleeton Springer



Providing **Disaster Response and Recovery Services** through **Program and Grants Management** since 2005.

- » Emergency Response and Operations
- » Emergency Protective Measures
- » Permanent Repair Projects
- » Grant Management
- » Program Management
- » Environmental Planning & Historic Preservation
- » State & Federal Agency Coordination

WWW.ROYAL.US

Reliable. Relentless. Results.



Huntsville Utilities

P.O. Box 2048
Huntsville, AL 35804-2048
112 Spragins Street
Huntsville, AL 35801
Phone: (256) 535-1200 ✈ Fax: (256) 535-1402
www.hsvutil.org

Utility Manager **Wes Kelley**
Title.....**President & CEO**
E-mail Address..... *wes.kelley@hsvutil.org*

Legal Counsel Daniel Kaufmann
Firm Name Huntsville Utilities
Address..... 112 Spragins Street, Huntsville, AL 35801
Telephone..... (256) 535-1203
Fax (256) 535-1402

Statistics

Regular Meeting of Board Fourth or last Wednesday in the month
Number of Employees 828
Utility Service Area 815 square miles, including all of Madison County
and a portion of Marshall and Jackson Counties
Total Electric Customers 233,456
Residential Customers 207,871
Commercial & Industrial Customers using less than 51 kW/month 22,313
Commercial & Industrial Customers using 51 – 4,999 kW/month 3,252
Gas Customers 65,012
Water Customers 109,796
Total System Assets (Electric Only) \$930,934,815.00
Miles of Line 4,788
Average Residential Usage 13,600 kWh/year
Number of Delivery Points 15
Miles of Electric Underground 2,036
Average Load Factor 57.98%
Power Supplier TVA

Key Staff

COO Chris Jones
CFO Melissa Marty
Assistant to President Vanessa Weatherly
Operations VP Mike Counts
Electric Operations Director Wayne Jordan
Fiber Operations Manager Jeff Stubblefield
Engineering VP Stacy Cantrell
Engineering Planning Director Glen Partlow
Operations Support VP Ron Rizzardi
Controller Donna Saunders
Purchasing Supervisor Melanie McClure
VP Employee Engagement (HR) Harry Hobbs
Safety & Security Director Dawn Renee Garner
External Affairs Joe Gehrdes

SOUTH SOURCE SALES

A female-owned manufacturer's representative and distributor built on values, integrity, and honor.

- Modular Connections
- SAE Towers
- efacec
- Exponential Power
- HARDCRAFT
- TESCO
- ESTEX
- QEI Automation Solutions
- Albarrie
- Fibergrate Composite Structures
- AccuGrid
- Ranger Power Quality
- EGM Electrical Grid Monitoring
- Wood Owl



Contact Us!



Phone Number:
205.612.2151



Website:
southsourcesales.com



City of LaFayette Electric Department

P.O. Box 87

LaFayette, AL 36862-0087

201 4th Place SE

LaFayette, AL 36862

Phone: (334) 864-9581 ✈ Fax: (334) 864-2205

www.cityoflafayetteal.com

Utility Manager **Kenneth Vines**
Title.....**Mayor**
E-mail Address.....kvines@cityoflafayetteal.com

Legal Counsel Joseph (Mac) Tucker
Address..... 213 Avenue A SE, LaFayette, AL 36862
Telephone..... (334) 864-0090
Fax (334) 864-7180

Statistics

Regular Meeting of Board..... 2nd & 4th Monday
Number of Employees..... 4
Utility Service Area LaFayette City Limits
Total Electric Customers 1,526
Residential Customers 1,275
Commercial & Industrial Customers using less than 51 kW/month..... 229
Commercial & Industrial Customers using 51 – 4,999 kW/month..... 22
Water Customers 1,417
Total System Assets..... \$5,539,045.00
Miles of Line..... 40
Average Residential Usage..... 11,321 kWh/year
Number of Delivery Points 2
Miles of Electric Underground..... 0.5
Average Load Factor..... Not Reported
Power Supplier AMEA

Key Staff

Superintendent Chris Sanders (csanders@cityoflafayetteal.com)
Lineman/Foreman (Asst. Superintendent) Anthony Smith (asmith@cityoflafayetteal.com)
Lineman Steve Golden
Apprentice Dylan Hill



**PROVIDING
KNOWLEDGE
TO POWER
YOUR FUTURE**

CONTACT US FOR ALL YOUR SAFETY TRAINING NEEDS



CUSTOMIZABLE PROGRAMS

We specialize in certifications, safety training, and work site audits.



VAST NETWORK

We connect you with industry professionals. Our experience ranges in several areas. Electrical safety, First Aid/AED, CDL Training, Osha Training, Flagger Training and many more topics.



PERSONAL CONSULTANT

We provide an unbiased and independent consultant allowing you to trust us with all your safety needs.



256-960-4705



www.bettersafetytraining.com

City of Lanett Electric Department

P.O. Box 290

Lanett, AL 36863-0290

401 North Lanier Avenue

Lanett, AL 36863

Phone: (334) 644-2141 ✈ Fax: (334) 644-5240

www.cityoflanett.com

Utility Manager **Allen Summers**
Title..... **Superintendent**
E-mail Address..... *asummers@cityoflanett.com*

Legal Counsel Stanley F. Gray
Firm Name Gray, Langford, Sapp, McGowan, Gray, Gray & Nathanson
Address..... 108 Fred Gray St, Tuskegee, AL 36083
Telephone (334) 727-4830

Statistics

Regular Meeting of Board..... 1st & 3rd Mondays of the month at 6:00 p.m.
Number of Employees..... 14
Utility Service Area Lanett City Limits
Total Electric Customers 3,045
Residential Customers 3,339
Commercial & Industrial Customers using less than 51 kW/month..... 350
Commercial & Industrial Customers using 51 – 4,999 kW/month..... 12
Gas Customers 985
Water Customers 2,466
Total System Assets Not Reported
Miles of Line..... 47
Average Residential Usage 31,871 kWh/year
Number of Delivery Points 1
Miles of Electric Underground..... Not Reported
Average Load Factor Not Reported
Power Supplier Energy Southeast

Key Staff

Executive Secretary/Personnel Officer..... Deborah Gilbert
Line Foreman..... Keith Lowery

A True Enterprise Experience



**Streamline Your Business.
Reduce Operational Costs. Increase Efficiency.
All With One Enterprise System.**

NISC's robust enterprise system features full integration across solutions that work across your organization.

Powerful Service, Financials, Operations and Marketing solutions can help you manage your meter data, analyze your customer data and offer payment and communication channels to increase customer satisfaction...All with one trusted partner.



www.nisc.coop

national information
solutions cooperative

Electric Board of the City of Luverne

P.O. Box 249
Luverne, AL 36049-0249
22 E. 5th Street
Luverne, AL 36049
Phone: (334) 335-3741 ✈ Fax: (334) 335-2206
www.luverne.org

Utility Manager **Merrill Sport**
Title..... **Electric Board Chairman**
E-mail Address..... *msport@huntchannel.tv*

Legal Counsel Michael E. Jones
Firm Name Jones & Coats
Address..... P.O. Box 367, Luverne, AL 36049-0367
Telephone (334) 335-6534
Fax (334) 335-2529

Statistics

Regular Meeting of Board 2nd Monday of 2nd month of each quarter
Number of Employees 5
Utility Service Area Luverne City Limits and Rutledge Town Limits
Total Electric Customers 1,857
Residential Customers 1,514
Commercial & Industrial Customers using less than 51 kW/month 244
Commercial & Industrial Customers using 51 – 4,999 kW/month 7
Water Customers 1,277
Total System Assets \$2,715,828.00
Miles of Line 77
Average Residential Usage 17,970,569 kWh/year
Number of Delivery Points 1
Miles of Electric Underground 1
Average Load Factor 80%
Power Supplier Energy Southeast

Key Staff

Mayor Ed Beasley
Electric Department Superintendant Brock Flynn
Engineering Manager Vacant
Accounting & Office Manager/Clerk Margie Gomillion
Customer Relations Manager Vicki Coggins



**CONNECTING
BUYERS AND
SELLERS
WORLDWIDE**



JJ Kane Auctions conducts online, public, absolute vehicle and equipment auctions across the U.S, making it easy to sell your used equipment. Our large and diverse auction inventory ranges from after-market heavy construction equipment, used cars and trucks, used service trucks, used pickup trucks, after-market bucket trucks, cranes and digger derricks.



CONTACT:
Dylan Evans
205-936-1094
dylan.evans@jjkane.com

jjkane.com
856-764-7163

Muscle Shoals Electric Board

P.O. Box 2547
Muscle Shoals, AL 35662-2605
1015 Avalon Avenue
Muscle Shoals, AL 35661
Phone: (256) 386-9290 ✈ Fax: (256) 386-9293
www.mseb.net

Utility Manager**Matt Bernauer**
Title.....**Manager**
E-mail Address.....*mbernauer@mseb.net*

Legal Counsel.....Jameson Hughston
Address.....406 W. Avalon Ave., Muscle Shoals, AL 35661
Telephone.....(256) 383-5707

Statistics

Regular Meeting of Board.....3rd Tuesday of each month, 4:30 p.m.
Number of Employees.....24
Utility Service Area.....Muscle Shoals City Limits & TVA Reservation
Total Electric Customers8,986
Residential Customers.....7,117
Commercial & Industrial Customers using less than 51 kW/month.....1,591
Commercial & Industrial Customers using 51 – 4,999 kW/month.....278
Total System Assets.....\$45,538,923
Miles of Line.....244
Average Residential Usage.....14,325 kWh/year
Number of Delivery Points3
Miles of Electric Underground.....62
Average Load Factor.....61.5%
Power Supplier.....TVA

Key Staff

Office Manager Dan Burns
Superintendent/Safety Coordinator Todd Cochran
Head Clerk..... Heather Gasque
Assistant Manager..... Kevin Buttrum



CAPE ELECTRICAL SUPPLY

**Electrical Utility
Wholesale Distributor**

**Excellent Service
and Quality Products**

18944 N. Jefferson Street
Athens, AL 35614

866-239-2603 Toll Free
256-353-0803 Phone
256-353-7019

www.capeelectric.com

Opelika Power Services

P.O. Box 2168
Opelika, AL 36803-2168
600 Fox Run Parkway
Opelika, AL 36801
Phone: (334) 705-5170 ✈ Fax: (334) 705-5148
www.opelikapower.com

Utility Manager **Brent Poteet**
Title **Director**
E-mail Address *bpoteet@opelika-al.gov*

City Legal Counsel Robbie Treese
Address P.O. Box 390, 207 S. 7th St., Opelika, AL 36803-0390
Telephone (334) 705-2075
Fax (334) 705-5515

Statistics

Regular Meeting of Board 1st & 3rd Tuesday each month
Number of Employees 33
Utility Service Area Opelika City Limits
Total Electric Customers 16,320
Residential Customers 13,898
Commercial & Industrial Customers using less than 51 kW/month 2,157
Commercial & Industrial Customers using 51 – 4,999 kW/month 266
Total System Assets \$73,669,000.00
Miles of Line Electric 469
Miles of Line Fiber 46
Average Residential Usage 18,000 kWh/year
Number of Delivery Points 9
Miles of Electric Underground 178
Average Load Factor 66.2
Power Supplier Energy Southeast/SEPA

Key Staff

Mayor Eddie Smith
City Administrator Joey Motley
Director Brent Poteet
Manager of Administrative Services Jessica Samuel
Administrative Coordinator Kristin Jones
Electrical Distribution Supervisor Kenton Lee
Sr. Engineering Representative Terry Coxell
Sr. Network Engineer Nathan Mallory
Facilities Manager Stacey Bryson



Distribution Engineering Solutions: Reliable, Resilient, Responsive

Engineering Design

- Professional Engineering Services
- Transmission & Distribution Line Design
- Distribution Field Design & Staking
- Pole Loading & Structure Analysis
- Project & Construction Management
- Right of Way & Easement Procurement
- Work Order Inspections
- DOT Project Design & Management

Joint Use Management

- Joint Utility Management Services
- Attachment Counts & Inventories
- Permitting & Make Ready Engineering
- Contract Negotiation & Administration
- NESC Compliant Audits

Geographic Information Systems

- GIS Mapping Services & Consulting
- AutoCAD Services
- GPS Integration

Energy Services

- Meter Install, Programming & Retrofits
- AMI Network Design & Deployment
- Smart Energy & Broadband Solutions

Storm Restoration

- Storm Response Planning
- Storm Damage Assessment

Brad Benson

Senior Vice President of
Distribution Engineering

Joel Mullinax

Vice President of Distribution
Operations

T: 770.947.4272 | TF: 800.897.8383 | F: 770.947.4277 | TRCcompanies.com

City of Opp Utilities Board

P.O. Box 610
Opp, AL 36467
109 East Hart Avenue
Opp, AL 36467
Phone: (334) 493-4571 ✈ Fax: (334) 493-6666
www.cityofopp.com

Utility Manager **Stacey Parker**
Title..... **General Manager**
E-mail Address..... *staceyp@opputilities.com*

Legal Counsel David Baker
Address..... 501 N. Main St., Opp, AL 36467
Telephone..... (334) 493-9716

Statistics

Regular Meeting of Board 3rd Tuesday of the month
Number of Employees 34
Utility Service Area Opp City Limits
Total Electric Customers 3,181
Residential Customers 2,667
Commercial & Industrial Customers using less than 51 kW/month 79
Commercial & Industrial Customers using 51 – 4,999 kW/month 33
Gas Customers Not Applicable
Total System Assets Electric only: \$12,240,000.00
Miles of Line 100
Average Residential Usage 13,800 kWh/year
Number of Delivery Points 3
Miles of Electric Underground 0
Average Load Factor 58%
Power Supplier PowerSouth

Key Staff

Electric Board Chairman Chance McCurley
Electric Board Member Joe Richburg
Electric Board Member LaVaughn Hines
Electric Board Member Skip Spurlin
Electric Board Member Chad Jackson

**Powerline Worker Training
Interpersonal Skills**

State-of-the-art training facilities and programs to enhance your career



Safety and Expertise

Industry-leading training ensures linemen are prepared for real-world challenges and advancement.

Courses Include:

- Training and Safety Overview
- Pre-Apprentice Lineman Program
- Powerline Workers Apprenticeship
- Comprehensive Underground School
- Line Locating and Fault Finding School
- Overhead Hotline School
- Advanced Lineworker Program
- Meterman Certification Program
- Foreman Development Series
- Storm Assessor Certification Program

A Culture of Teamwork

Strong interpersonal skills foster collaboration, increase productivity, and enhance both employee and customer satisfaction.

Courses Include:

- Interpersonal Skills Overview
- Basic Rates
- A Guide for New HR Leaders
- Excellence as a Supervisor
- Human Resources Advanced Series
- Utility Customer Service Training - Series 1
- Utility Customer Service Training - Series 2
- Utility Customer Service Leadership
- Utility Management Series



Electric Cities of Georgia

Sabrina Milner, Director, Communications
678.213.6092
smilner@ecoga.org | ecoga.org

THE *Smart* WAY TO GROW
YOUR UTILITY EMPLOYEES

City of Piedmont Electrical Department

P.O. Box 112
Piedmont, AL 36272
109 N. Center Avenue
Piedmont, AL 36272
Phone: (256) 447-3560 ✈ Fax: (256) 447-9067
www.piedmontcity.org/power-and-light/

Utility Manager **Corey Horton**
Title..... **Electrical Manager**
E-mail Address..... *corey.horton@piedmontcity.org*

Legal Counsel Ronald L. Allen
Firm Name Merrill, Merrill, Matthews & Allen
Address..... P.O. Box 36, Anniston, AL 36202
Telephone (256) 236-5063
Fax (256) 236-5065

Statistics

Regular Meeting of Board 1st & 3rd Tuesday of each month
Number of Employees 5
Utility Service Area Piedmont City Limits
Total Electric Customers 2,020
Residential Customers 1,715
Commercial & Industrial Customers using less than 51 kW/month 282
Commercial & Industrial Customers using 51 – 4,999 kW/month 23
Gas Customers 1,370
Water Customers 2,703
Total System Assets Not Reported
Miles of Line 52
Average Residential Usage 12,361 kWh/year
Number of Delivery Points 2
Miles of Electric Underground 2
Average Load Factor 68%
Power Supplier Energy Southeast

Key Staff

Electrical Manager Corey Horton
Water & Gas Manager Bryan Watts
Meter Department Dereck Kiser
City Clerk Tashia Blackerby

TOOLS BUILT FOR LINEMEN SERVICES BUILT FOR THE LONG HAUL

TOOL SALES

EQUIPMENT RENTALS

RUBBER GOODS TESTING & CLEANING

ROPE FABRICATION & ROPE REPAIR

TOOL REPAIR & REFURBISHMENT

**FIBERGLASS TESTING, REPAIR &
REFINISHING**

**GROUND & JUMPER SETS
MANUFACTURING & REPAIR**



(877) 860-5666 • TALLMANEQUIPMENT.COM



Robertsdale Electric Department

P.O. Box 429

Robertsdale, AL 36567-0429

Phone: (251) 947-8900 ✈ Fax: (251) 947-2619

www.robertsdale.org

Utility Manager **Ruthie Campbell**

Title **Mayor**

E-mail Address *mayor@robertsdale.org*

Legal Counsel Ken Raines

Firm Name Raines Law Firm

Address P.O. Box 453, Fairhope, AL 36533

Telephone (251) 517-0528

Fax (251) 517-0522

Statistics

Regular Meeting of Board 1st & 3rd Mondays of the month

Number of Employees 90

Utility Service Area Robertsdale City Limits

Total Electric Customers 3,558

Residential Customers 3,087

Commercial & Industrial Customers using less than 51 kW/month 607

Commercial & Industrial Customers using 51 – 4,999 kW/month 218

Gas Customers 216

Water Customers 4,551

Sewer Customers 3,770

Total System Assets \$11,800,000.00

Miles of Line 90

Average Residential Usage 13,958 kWh/year

Number of Delivery Points 1

Miles of Electric Underground (Primary: 15.4; Secondary: 5.6) 21

Average Load Factor 59%

Power Supplier MEAG

Key Staff

City Clerk Shannon Burkett

Public Works Director Scott Gilbert

Electric Foreman Scott Bankester



▶ **NEED ASSET MANAGEMENT OR PREVENTATIVE MAINTENANCE?
WE SAY YES!**

TRANSFORMERS

- ▶ Dress and Test
- ▶ Annual Testing
- ▶ LTC Maintenance
- ▶ Turnkey Installations
- ▶ Relocations
- ▶ FR3 Retrofills
- ▶ Leak Repairs
- ▶ N2 Systems

ENGINEERED SOLUTIONS

- ▶ Protection and Control Engineering
- ▶ System Planning
- ▶ Power Quality
- ▶ Arc Flash Analysis
- ▶ SF6 & OCB PM Expertise
- ▶ Relay Testing
- ▶ NERC / FERC Testing & Documentation



SUNBELT SOLOMON

Daresa Denis

daresa.denis@sunbeltsolomon.com | 423.453.0420

Visit us at SunbeltSolomon.com

Russellville Electric Board

P.O. Box 1148
Russellville, AL 35653-1148
721 South Jackson Avenue
Russellville, AL 35653
Phone: (256) 332-3850 ✈ Fax: (256) 332-3027
www.russellvilleutilities.com

General Manager **Derrick Moore**
Title..... **General Manager**
E-mail Address..... *dmoore@relebd.com*

Legal Counsel Jeff Bowling
Firm Name Rogers, Bowling & McReynolds
Address..... P.O. Box 669, 303 N. Jackson Ave., Russellville, AL 35653

Statistics

Regular Meeting of Board 3rd Tuesday of the month
Number of Employees 21
Utility Service Area Russellville City Limits
Total Electric Customers 5118
Residential Customers 3929
Commercial & Industrial Customers using less than 51 kW/month..... 1037
Commercial & Industrial Customers using 51 – 4,999 kW/month..... 94
Total System Assets \$27,010,702.17
Miles of Line 122
Average Residential Usage kWh/month 790
Number of Delivery Points 2
Miles of Electric Underground..... Not Reported
Average Load Factor 64%
Power Supplier TVA

Key Staff

Accountant Tiffany Holt
Superintendent Craig Grissom
Foreman..... Jerry Sutton



Customers.

First.

Always.

Since 1926.

Scottsboro Electric Power Board

P.O. Box 550
Scottsboro, AL 35768-0550
404 East Willow Street
Scottsboro, AL 35768
Phone: (256) 574-2680 ✉ Fax: (256) 574-5085
www.sepb.net

Utility Manager **Stacy Radon**
Title.....**Manager**
E-mail Address..... *sradon@sepb.net*

Legal Counsel John F. Porter, III, P.C.
Firm Name The Porter Law Group, P.C.
Address 123 East Laurel, Scottsboro, AL 35768
Telephone (256) 574-5156
Fax (256) 574-6552

Statistics

Regular Meeting of Board 1st Wednesday of the month
Number of Employees 40
Utility Service Area 58 Square Miles
Total Electric Customers 8,815
Residential Customers 7,143
Commercial & Industrial Customers using less than 51 kW/month..... 1,471
Commercial & Industrial Customers using 51 – 4,999 kW/month..... 201
Cable TV Customers 2,405
Internet Customers 5,083
Total System Assets \$50,070,070.13
Miles of Line..... 307
Average Residential Usage 14,389 kWh/year
Number of Delivery Points 2
Miles of Electric Underground..... 64
Average Load Factor..... 67.48%
Power Supplier TVA

Key Staff

Electric Superintendent Pat Thompson
Finance Manager Emma Moore
Marketing Cheyann Woodall
Customer Service Manager Jordan Slaten
Safety Pat Thompson
Purchasing Agent/Fleet Casey Ivey
Billing Manager Amanda Justice



Central
Service
Association

*Empowering
your VISION*

CENTRALVIEW

ERP solutions for the future

- CIS/Billing/Financials
- Engineering/Operations
- Customer Engagement/
Payment



csa1.com



Sheffield Utilities

P.O. Box 580

Sheffield, AL 35660-0580

300 N. Nashville Avenue

Sheffield, AL 35660

Phone: (256) 389-2000 ✈ Fax: (256) 383-6727

www.sheffieldutilities.org

Utility Manager **Steve Hargrove**
Title..... **General Manager**
E-mail Address..... *shargrove@sheffieldutilities.org*

Legal Counsel..... Steve Baccus
Firm Name Almon, McAlister, Baccus & Worsham LLC
Address..... 505 N. Columbia Ave., Suite A, Sheffield, AL 35660
Telephone..... (256) 383-4448
Fax..... (256) 383-6523

Statistics

Regular Meeting of Board..... Last Wednesday of the month
Number of Employees..... 67
Utility Service Area..... Colbert County, excluding cities of Tuscumbia & Muscle Shoals
Total Electric Customers 19,294
Residential Customers..... 15,673
Commercial & Industrial Customers using less than 51 kW/month..... 3,350
Commercial & Industrial Customers using 51 – 4,999 kW/month..... 271
Gas Customers..... 3,637
Water Customers 4,964
Total System Assets..... \$88,229,792.20
Miles of Line..... 1,744
Average Residential Usage..... 15,540 kWh/year
Number of Delivery Points 7
Miles of Electric Underground..... 154
Average Load Factor..... 69.7%
Power Supplier..... TVA

Key Staff

Chief Financial Officer..... Matt Parker
Purchasing Agent..... Ginger Hubbard
Customer Service Director Eric Gifford
Safety Director Christopher White
Electrical Operations Manager..... Michael Joe Waldrep
IT Specialist..... Michael Rogers
Administrative Assistant..... Minnice Wallace
Assistant General Manager..... Tyler Jones



**INTEGRATED
SOLUTIONS
DIVISION**

Fully Charged Solutions

Nathan Jones
Territory Manager
Swift Industrial Power
205.616.1226 – Mobile Line
www.SWIFTPOWER.com

Sylacauga Utilities Board

P.O. Box 207

Sylacauga, AL 35150-0207

301 North Elm Street

Sylacauga, AL 35150

Phone: (256) 249-8501 ✈ Fax: (256) 401-2528

www.sylacauga.net

Utility Manager **Mitch Miller**

Title..... **General Manager & CEO**

E-mail Address..... *mmiller@sylacauga.net*

Legal Counsel..... William T. Campbell

Firm Name McKay & Campbell

Address..... 400 West Third Street, Sylacauga, AL 35150

Telephone..... (256) 245-5267

Fax (256) 245-5268

Statistics

Regular Meeting of Board..... 3rd Monday of the month

Number of Employees..... 61

Utility Service Area 15 square miles: Sylacauga City Limits and surrounding area

Total Electric Customers 6,026

Residential Customers..... 5,114

Commercial & Industrial Customers using less than 51 kW/month..... 698

Commercial & Industrial Customers using 51 – 4,999 kW/month..... 214

Gas Customers 5,151

Water Customers 7,473

Wastewater Customers..... 4,627

Internet Customers..... 1,243

Data Customers..... 5

Total System Assets..... \$163,909,839

Miles of Line..... 211

Average Residential Usage..... 1,059 kWh/month

Number of Delivery Points 3

Miles of Electric Underground..... 34

Average Load Factor 65%

Power Supplier Energy Southeast\SEPA

Key Staff

Office Manager Emily Culberson

Operations Director Eric Carithers



Taylor

ELECTRIC

SINCE 1972

An Experienced Electric Utility Construction and Maintenance Contractor

- Overhead and Underground Distribution
- Construction and Maintenance
- Substation and Transmission Line Construction
- Commercial and Industrial Maintenance
- Storm Restoration
- Fiber Optic Construction
- Outdoor Lighting
- GIS Mapping Services



256-895-0941

www.taylorelectricutility.com

Tarrant Electric Department

P.O. Box 170220
Tarrant, AL 35217-0220
1700 Pinson Street
Tarrant, AL 35217

Phone: (205) 841-0271 ✉ (205) 849-2800 Ext. 7
www.cityoftarrant.com/electric-dept.html

Utility Manager **Zack Hall**
Title..... **Interim General Manager**
E-mail Address..... zball@cityoftarrant.com

Legal Counsel Bobby Poundstone
Firm Name Bradley Arant Boult Cummings, LLP
Address..... 445 Dexter Avenue, Suite 9075, Montgomery, AL 36104
Telephone (334) 956-7645
Fax (334) 956-7845

Statistics

Regular Meeting of Board 2nd Tuesday of the month
Number of Employees 14
Utility Service Area Tarrant City Limits
Total Electric Customers 2,729
Residential Customers 2,169
Commercial & Industrial Customers using less than 51 kW/month 504
Commercial & Industrial Customers using 51 – 4,999 kW/month 56
Gas Customers Not Applicable
Water Customers Not Applicable
Total System Assets \$12,323,933.00
Miles of Line 59
Average Residential Usage 13,084 kWh/year
Number of Delivery Points 1
Miles of Electric Underground 0
Average Load Factor 55%
Power Supplier TVA

Key Staff

Principal Administrative Analyst..... Reshonda McNeal (rmcneal@cityoftarrant.com)

THE OKOGUARD[®] ADVANTAGE

Introduced by Okonite, with nearly 50 years of service history - Okoguard EPR cables have become the standard of unequalled excellence in power cables.

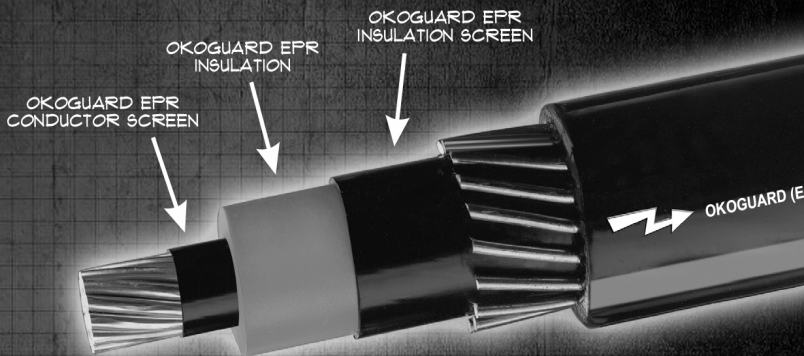

Only Okoguard cables have the distinction in the industry to provide an all EPR insulation system, ensuring unmatched cable reliability for your underground infrastructure.

Okoguard's design, service history and uncompromising standards offer confidence in the lifetime performance of your underground cable.

Okonite - With over 138 years of specialized service to the electrical utility industry, is still the leader in innovation and technology.

OKOGUARD ADVANTAGES:

- ✓ SUPERIOR PERFORMANCE
- ✓ OUTSTANDING RELIABILITY
- ✓ MORE FLEXIBILITY
- ✓ ALL EPR INSULATION SYSTEM
- ✓ NO TREEING
- ✓ TRIPLE TANDEM EXTRUSION

Okonite Cables...A higher Standard!



**THE
OKONITE
COMPANY**

US Highway 11, Suite 101
Springville, AL 35146

(205) 655-0390 Fax: (205) 655-0393



City of Troy Utilities

P.O. Box 549
Troy, AL 36081-0549
306 E. Academy Street
Troy, AL 36801
Phone: (334) 566-0177 ✈ Fax: (334) 670-6061
<http://www.troyal.gov/Utilities>

Utility Manager **Brian M. Chandler, PE**
Title..... **General Manager**
E-mail Address..... *brian.chandler@troyal.gov*

Legal Counsel Richard Calhoun
Firm Name Calhoun, Faulk, Curtis & Faircloth, LLC
Address..... P.O. Box 489, Troy, AL 36081
Telephone (334) 566-7200

Statistics

Regular Meeting of Board..... 2nd & 4th Tuesday of each month - City Council
Number of Employees..... 66
Utility Service Area Troy City Limits
Total Electric Customers 9,739
Residential Customers 7,838
Commercial & Industrial Customers using less than 51 kW/month..... 1,427
Commercial & Industrial Customers using 51 – 4,999 kW/month..... 13
Commercial & Industrial Customers using more than 4,999 kW/month..... 22
Water Customers 8,420
Total System Assets \$35,708,051
Miles of Line..... 309
Average Residential Usage 1,006 kWh/month
Number of Delivery Points 1
Miles of Electric Underground..... 89.64
Average Load Factor 72%
Power Supplier Exelon

Key Staff

Assistant General Manager Solomon Brackett
Water and Wastewater Engineer Ethan Mount
Executive Assistant Karen Dillard
Staking Technician Kevin Jordan
General Foreman Blake Garrett
Foreman Chris Niday
Foreman Hue Davis
Warehouse Manager Justin Carroll
AMI Coordinator Danny Lee
Office Manager Gabby Law
UAS Coordinator Chase Collins

Jackson Line Clearing

Andy McMillan, President

- Right-of-way clearing
- Herbicide spraying
- Vegetation maintenance
- Tree trimming
- Modern technology and innovative practices

118 N. Royal Street, Suite #602
Mobile, AL 36602
(251) 533-4312

office@jacksonlineclearing.com

Tuscumbia Utilities

P.O. Box 269
Tuscumbia, AL 35674-0269
202 E. 6th Street
Tuscumbia, AL 35673
Phone: (256) 383-0321 ✈ Fax: (256) 386-5690
www.tuscutilities.com

Utility Manager **Jeff McDonald**
Title..... **General Manager**
E-mail Address..... *jmcdonald@tuscutilities.com*

Legal Counsel James Hughston
Firm Name Hughston & Hughston
Address..... P.O. Box 70, Tuscumbia, AL 35674
Telephone (256) 383-5707
Fax (256) 383-5759

Statistics

Regular Meeting of Board 2nd Monday of the month
Number of Employees 31
Utility Service Area Tuscumbia City Limits
Total Electric Customers 5,498
Residential Customers 4,028
Commercial & Industrial Customers using less than 51 kW/month 894
Commercial & Industrial Customers using 51 – 4,999 kW/month 56
Gas Customers 3,047
Water Customers 5,484
Wastewater Customers 4,806
Total System Assets \$48,591,075
Miles of Line 142
Average Residential Usage 13,116 kWh/year
Number of Delivery Points 1
Miles of Electric Underground 8.5
Average Load Factor 68%
Power Supplier TVA

Key Staff

Electrical Superintendent Brian Thompson
Gas Superintendent Ben Wilson
Assistant Manager Donna Ellison
Water Superintendent Brian Myrick
Head Accountant Melinda Wallace

Connecting Alabama to More Speed, Savings and Reliability.

At Dragonfly, we believe better broadband starts with trust. We're committed to equipping previously underserved communities for the future with wireless and fiber infrastructure. Our residential and business customers alike benefit from locally based customer support and uncompromising service.

**Because that's how we do
internet in Alabama.**



Dragonfly
INTERNET
877-249-4647



Discover the difference local makes at Dragonfly.net.

Utilities Board of the City of Tuskegee

P.O. Box 831050
 Tuskegee, AL 36083
 204 W. Lee Street
 Tuskegee, AL 36083
 Phone: (334) 720-0700
www.yourubt.com

Utility Manager **Gerald Long**
Title **General Manager**
E-mail Address *glong@yourubt.com*
 Legal Counsel Milton C. Davis
 Address 304 North Main St., Tuskegee, AL 36083
 Telephone (334) 727-6500

Statistics

Regular Meeting of Board 1st Monday of the month
 Number of Employees **73**
 Utility Service Area Tuskegee City, Town of Franklin and the Town of Shorter
 Total Electric Customers 6,608
 Residential Customers 5,786
 Commercial & Industrial Customers using less than 51 kW/month 641
 Commercial & Industrial Customers using 51 – 4,999 kW/month 181
 Water Customers 3,800
 Total System Assets \$65,180,395.82
 Miles of Line 103 sq miles
 Average Residential Usage 820 kWh/month
 Number of Delivery Points 3
 Miles of Electric Underground 0
 Average Load Factor Not Reported
 Power Supplier Energy Southeast

Key Staff

Assistant General Manager N/A
 Chief Financial Officer Gerald Long
 Operations Officer Kenneth Sinclair
 Light & Power Supervisor Alvin Woods
 Engineering Manager Christopher Thompson
 Foreman Larry Hale

MAKE ONE LOCAL CALL

TO SERVE ALL OF YOUR TRANSFORMER NEEDS

Our nationwide network of EPA-TSCA permitted facilities are strategically located near our customer base to provide a full suite of products and services.



- STOCK SALES
- PCB DISPOSAL
- REPAIRS
- FIELD DECOMMISSIONING
- FIELD TECHNICAL SERVICES
- OIL PROCESSING & RECYCLING



CONTACT US TODAY FOR A QUOTE OR TO SCHEDULE A PICK-UP

Emily Church | 706.366.4190 | echurch@emeraldtransformer.com

Lee Megois | 205.475.4700 | lmegois@emeraldtransformer.com



ELECTRIC CITIES
OF ALABAMA

POWER
PROVIDERS



Energy Southeast

Energy Southeast is a public corporation of the State of Alabama. Energy Southeast was created in 1981 for the primary purpose of securing an adequate, dependable and economical power supply for its participating Members. Energy Southeast sells power to each of its 11 participating Members, which consist of municipalities, utility boards and an electric board. Each Member owns and operates its own electric distribution system.

Mission Statement

Energy Southeast's mission is to provide for our Member communities a reliable and economical source of electric power, enabling them to preserve and enhance the benefits of municipal utility ownership for their citizens and the electric customers they serve. We strive to offer services that our Members need and can adapt to provide the best value for their communities and customers.

Power Supply and Other Services

Energy Southeast has power supply contracts and also owns the Energy Southeast-Sylacauga Peaking Plant, consisting of two simple-cycle gas turbine generating units with a combined rating of 95MW. This power plant supplements the power supply needs of its Members, who also receive power from the Southeastern Power Administration (SEPA). Energy Southeast's Members have appointed Energy Southeast as their agent for all matters pertaining to their SEPA contracts.

Some of Energy Southeast's Member services include:

- Cost of Service Studies
- Regulatory Compliance Support and Coordination
- Territorial Legal and Engineering Support
- Distribution Services
- Joint Action Services Working Group
- Communications and Marketing Support
- Scholarship Program
- Economic Development Support Programs
- Hometown Connections® Affiliate
- American Public Power Association (APPA) Membership for Members
- APPA's Demonstration of Energy & Efficiency Developments (DEED) Membership for Members
- Electric Cities of Alabama Membership for Members
- TVPPA Affiliate Membership for Members
- Training and Safety Support Services and Distribution Technology Support

Energy Southeast's Electric Cities Members

- Alexander City
- Dothan
- Fairhope
- Foley
- LaFayette
- Lanett
- Luverne
- Opelika
- Piedmont
- Sylacauga
- Tuskegee

Energy Southeast

80 TechnaCenter Drive, Suite 200 | Montgomery, AL 36117
(334) 262-1126 | (334) 262-2267 (fax) | www.energysoutheast.com

Board of Directors

Chairman	Gary Fuller, <i>City of Opelika</i>
Vice Chairman	Louis Davidson, <i>City of LaFayette</i>
Secretary-Treasurer	Harold Washington, <i>Utilities Board of Tuskegee</i>
Director	Jack Burrell, <i>City of Fairhope</i>
Director	David Crutchfield, <i>City of Dothan</i>
Director	Mike Densmore, <i>City of Alexander City</i>
Director	Jamie Heard, <i>City of Lanett</i>
Director	Corey Horton, <i>City of Piedmont</i>
Director	Elliott Jones, <i>Electric Board of the City of Laverne</i>
Director	Mitch Miller, <i>Sylacauga Utilities Board</i>
Director	Brian Skelton, <i>Riviera Utilities</i>

Executive Leadership

President & CEO	Fred D. Clark, Jr. <i>fclark@energysoutheast.com</i>
Executive Assistant & Board Secretary	Samantha Alexander <i>samantha@energysoutheast.com</i>
Executive VP and Chief Operating Officer	Peter Thompson <i>peter@energysoutheast.com</i>
Executive VP and Chief Financial Officer	Logan Remson <i>logan@energysoutheast.com</i>
Vice President of Compliance & Distribution Services	Mark Ennis, P.E. <i>mennis@energysoutheast.com</i>
Vice President of Transmission & Distribution Technology Support	Arthur Bishop <i>art@energysoutheast.com</i>
Vice President of Public Affairs	Michelle Walden <i>michelle@energysoutheast.com</i>
Vice President of Generation Assets	Ronald Ray <i>ron@energysoutheast.com</i>

Tennessee Valley Authority



TVA is a wholesale provider of electricity to 153 municipal and cooperative electric distributors located in the Tennessee Valley.

The TVA service area encompasses 80,000 square miles and includes most of Tennessee and parts of Alabama, Mississippi, Kentucky, Virginia, North Carolina and Georgia.

TVA's corporate headquarters are in Knoxville, TN. Its power operations headquarters is based in Chattanooga, TN and its External Relations organization is based in Nashville, TN.

Huntsville

Customer Service Center
4950 Corporate Drive NW
Huntsville, AL 35801
(256) 430-4800

Kevin Chandler

General Manager, Customer
Delivery
(256) 386-2614
kcchandler@tva.gov

Robby Jones

Customer Service Manager
(256) 430-4844
jrjones@tva.gov

Alan South

Customer Service Manager
(256) 386-2336
acsouth@tva.gov

Electric Cities Customers

Albertville Municipal Utility Board
Athens Utilities
Bessemer Electric Service
Courtland Electric Department
Cullman Power Board
Decatur Utilities
Florence Utilities
Fort Payne Improvement Authority
Guntersville Electric Board

Hartselle Utilities
Huntsville Utilities
Muscle Shoals Electric Board
Russellville Electric Board
Scottsboro Electric Power Board
Sheffield Utilities
Tarrant Electric Department
Tuscumbia Electricity Dept.

TVA in Alabama

- TVA covers 8,979 square miles of Alabama with 6,826 miles of watershed management. Local power companies (LPCs) distribute TVA in 17 Alabama counties.
- TVA sold 18.6 billion kilowatt-hours of electricity to 17 municipalities and 8 co-ops in Alabama.
- TVA provided 7.84 billion kilowatt-hours of electricity to 510,000 households through LPCs in Alabama.
- TVA served 9.79 billion kilowatt-hours of electricity to 102,000 Commercial and Industrial Customers through LPCs.
- TVA generated \$1.6 billion in power revenue in Alabama in 2019. That comprises 14.1% of TVA's total operating revenue.
- In Alabama, TVA operates three hydroelectric dams (Guntersville, Wheeler and Wilson), one nuclear power plant (Browns Ferry) and one natural gas-fueled combustion turbine site (Colbert), with a combined generating capacity of more than 4,870 megawatts.
- TVA operates two solar facilities in Alabama—a 23-kilowatt site at the Huntsville Botanical Gardens and a 36-kilowatt site at the Florence wastewater treatment facility.

Executive Leadership

- Don Moul, President & CEO
- Will Trumm, Executive Vice President, Chief Administrative and Federal Affairs Officer
- Tom Rice, Executive Vice President and Chief Financial Officer
- Laura J. Campbell, P.E., Senior Vice President and Chief of Staff
- Matt Rasmussen, Senior Vice President and Chief Nuclear Officer
- Allen Clare, Senior Vice President, Generation
- Bryan Williams, Senior Vice President, Generation Projects and Fleet Services
- Greg Henrich, Senior Vice President, Transmission

Board of Directors

TVA has a part-time Board appointed by the President and confirmed by the Senate for five-year terms.

- Mitch Graves, Memphis, TN, Chair
- Jeff Hagood, Knoxville, TN, Chair-Elect
- Art Graham, Jacksonville, FL
- Randy Jones, Guntersville, AL
- Bobby Klein, Chattanooga, TN
- Wade White, Eddyville, KY





Constellation®

1310 Point Street | Baltimore, MD 21231
(713) 401-2292 | www.constellation.com

Constellation Executive Leadership

Joseph Dominguez – President and Chief Executive Officer
Kathleen L. Barron - Executive VP and Senior Advisor to the CEO
David Dardis – Senior Executive Vice President
Emily Duncan – Senior Vice President of Strategy & Corporate Affairs
Daniel L. Eggers – Senior Executive Vice President of Finance
Bryan Hanson – Senior Executive VP and Chief Generation Officer
Mike Koehler - Executive VP and Chief Administration Officer
James McHugh – Senior Executive VP and Chief Commercial Officer
Susie Kutansky - Executive VP and Chief Human Resources Officer
Matthew Price - Executive Vice President and Chief Legal Officer
Judy Rader – Senior Vice President, Corporate Affairs and Chief Communications Officer

Southeast Origination Staff

Brian Davison - Senior Originator, Southeast, Constellation
Brian.Davison@constellation.com | (713) 401-2292 | (410) 206-6032 (cell)

Constellation, is a leading competitive energy company providing power, natural gas, renewable energy, and energy management products and services for homes and businesses across the continental United States. We provide integrated energy solutions — from electricity and natural gas procurement and renewable energy supply to energy efficiency and distributed energy solutions — that help customers strategically buy, manage and use their energy. Constellation currently serves wholesale full requirements electricity and related load serving products to various customers that do not own sufficient generating capacity or have in-house supply functions to serve their own load requirements. In addition, Constellation owns the 750 MW Hillabee Energy Facility in Alexander City, Alabama and owns one of the nation’s largest and cleanest power generation fleets, with approximately 35,000 megawatts of owned power generation, including more than 19,000 megawatts of nuclear power.

Constellation’s Electric Cities Members

City of Troy



POWERSOUTH ENERGY COOPERATIVE

2027 East Three Notch Street | Andalusia, AL 36421
(334) 427-3000 | (334) 222-3860 (fax) | www.powersouth.com

PowerSouth Executive Leadership

- **President & CEO**
Gary Smith, gary.smith@powersouth.com
- **Executive Vice President and Chief Operating Officer**
Damon Morgan, damon.morgan@powersouth.com
- **Executive Vice President & CFO**
Beth Woodard, beth.woodard@powersouth.com
- **Senior Vice President, External Affairs**
Horace Horn, horace.horn@powersouth.com
- **Vice President, Legal & Corporate Affairs**
Art Brunson, art.brunson@powersouth.com
- **Vice President, Member Services & Communications**
Courtney Bowers, courtney.bowers@powersouth.com

PowerSouth Energy Cooperative, headquartered in Andalusia, Ala., is a generation and transmission electric cooperative that serves the wholesale power needs of 20 distribution members, 16 electric cooperatives and four municipal electric systems in Alabama and northwest Florida.

PowerSouth provides a variety of services to its member-owners and offers assistance in strategic planning, load forecasting and residential consumer surveys; marketing and economic development, advertising support; safety programs and training; and computer network support.

PowerSouth's Electric Cities Members

Andalusia
Elba

Brundidge
Opp



Alabama Power

Alabama Power is a regulated investor-owned utility that provides retail electric service to 1.5 million homes, businesses, and industries in the southern two-thirds of Alabama. Alabama Power is part of Southern Company, a leading U.S. energy company serving nine million customers and businesses nationwide.

Alabama Power owns 81 electric generating units located at 24 power plants in the state with a total nameplate capacity of more than 11,500 megawatts. More than 85,000 miles of power lines carry electricity to customers throughout 45,000 square miles of service territory.

Alabama Power takes its responsibility to protect the environment seriously. They have a strong record of meeting or exceeding standards set by state and federal environmental agencies and routinely rank among the top of all investor-owned utilities for its investment in equipment and technology to safeguard the environment. Alabama Power is committed to preserving the beauty, richness and diversity of Alabama's natural landscape.

Southern Company supports 9 million customers and businesses nationwide with electric utilities in three states (Alabama, Georgia and Mississippi) and natural gas distribution utilities in four, and provides wholesale energy, customized distributed energy solutions and fiber optics and wireless communications across the country.

Alex McCrary

Alabama Power

600 North 18th Street

17 N-0672

Birmingham, AL 35203

Telephone: (205) 257-3301 | abmccrar@southernco.com

Alabama Power's Electric Cities Members

City of Evergreen

ELECTRIC CITIES OF ALABAMA 2026 DIRECTORY



A FISHER ARNOLD
ENGINEERS | ARCHITECTS | CONSULTANTS | PLANNERS

www.fisherarnold.com
1.888.583.9724





OUR SERVICE CENTER SAVED CLIENTS OVER \$470,000 LAST YEAR.

Find out how you can start saving with IUC.



All calls are answered in the US by live, trained, dispatch agents.



All calls are verified, qualified and prioritized—reduces unnecessary crew dispatches.



Faster response time from our Georgia-based contact center during outages.

CALL SERVICES • DISPATCHING • CONNECTIONS • NOTIFICATIONS



INTERACTIVE UTILITY COMMUNICATIONS

844-679-3714 | sales@iucsolution.com
IUCSOLUTIONS.COM



ELECTRIC CITIES
OF ALABAMA

**ASSOCIATE
MEMBERS**

Associate Membership Information

CORPORATE ASSOCIATE MEMBERSHIP

- ◆ \$1,500 Annually
- ◆ Organization is Association Member (up to five individuals)

INDIVIDUAL ASSOCIATE MEMBERSHIP

- ◆ \$1,000 Annually
- ◆ One Individual is the Association Member

All corporations and individuals requesting ECA Associate Membership will be required to complete an application. This application will be reviewed by the ECA Board of Directors for consideration and approval at the next scheduled Board of Directors meeting.

ASSOCIATE MEMBER BENEFITS

- ✦ **ELECTRIC CITIES ANNUAL MEETING INVITATION:** To be held July 5-8, 2026, at The Lodge at Gulf State Park in Gulf Shores, Ala. Associate members are charged the same registration fee as regular members. Sponsorships will not be required for associate members, however, additional sponsorships are available.
- ✦ **ELECTRIC CITIES ENGINEERING & OPERATIONS CONFERENCE:** To be held October 19-21, 2026, at Renaissance Ross Bridge in Hoover, Ala. Open to member cities, power suppliers, cooperatives, associate members and vendors to the utility industry.
- ✦ **ELECTRIC CITIES WEBSITE:** www.electrincities.org Associate members will have access to the association's website and will be listed on the *Associate Members* page, with appropriate links to their websites and/or e-mail addresses.

✦ **ELECTRIC CITIES MEMBERSHIP DIRECTORY:** Published annually. Associate members will benefit from the following:

- ◆ One full page advertisement at no additional cost. (a current \$500 cost to non-members)
- ◆ Receive one hard copy of the directory for each Associate Member along with a PDF version.
- ◆ Listing in the ***Associate Members*** section of the directory. This listing will include company information, contact names, addresses and phone numbers.
- ◆ Additional listing in the ***Advertiser's Index*** in the directory.

✦ **OTHER TRAINING PROGRAMS:** Will be open to associate members. Associate members may be called upon to provide instruction at future training events.

✦ **SPONSORSHIP OPPORTUNITIES:** Associate members will have right of first refusal for all sponsorship opportunities that may arise during the course of Electric Cities continued development.

ASSOCIATE MEMBER LIMITATIONS:

Associate members are non-voting members of the association; therefore, they may not attend association business meetings, legislative meetings. Conferences or other events of the association ***unless by express, written invitation of the Executive Director.*** Without such invitation, Board. Legislative functions and other business meetings of the association will be limited to regular members only.

Associate Members

✈ **Alabama 811**

3104 Bates Lane | Fultondale, AL 35068
(205) 731-3200 | (205) 731-3249 (fax) | www.al811.com

Annette Bowman, Executive Director

(205) 731-3209 | abowman@al811.com

McKay Lyvers, Managing Director of Public Awareness and Membership

(205) 731-3207 | mlyvers@al811.com

Primary Goods/Services:

Alabama 811 is a non-profit, membership organization that operates the statewide underground damage prevention program to assist excavators and the general public to protect underground facilities from third party damage due to excavation activities.

✈ **Alabama Municipal Insurance Corporation**

110 North Ripley Street | Montgomery, AL 36104
(334) 386-3863 | (334) 386-3873 (fax) | www.amicentral.org

Aaron Reeves, Account Executive |

(334) 386-4244 | areeves@amicentral.org

Amanda Golson, Account Executive

(334) 386-4258 | agolson@amicentral.org

Mike Gardner, Account Executive

(334) 386-4250 | mikeeg@amicentral.org

Sean Duke, President

(334) 386-4220 | sduke@amicentral.org

Will Strength, Loss Control Manager

(334) 386-8111 | wstrength@amicentral.org

Primary Goods/Services:

The Alabama Municipal Insurance Corporation (AMIC) is a mutual insurance company organized under the laws of the State of Alabama and owned by its participating Alabama member municipalities.

✦ **Allen & Hoshall, Inc.**

Scott Burleson, Senior VP

1661 International Drive, Suite 100 | Memphis, TN 38120

(901) 820-0820 | www.allenhoshall.com | sburleson@allenhoshall.com

Primary Goods/Services:

Allen & Hoshall, founded in 1915, is recognized as a premier design firm dedicated to our clients. We study, plan, and design electric utility projects, infrastructure, transportation, and building systems. Our staff of more than 100 professionals assures you that every detail of your project receives attention from a specialist.

✦ **Altec Industries, Inc.**

33 Inverness Center Pkwy, Ste. 110 | Birmingham, AL 35242

(205) 243-5000 | www.altec.com

Jay Hale, Area Manager

(205) 243-5000 | jay.hale@altec.com

Jason Janoulis, Sr. Account Manager

(205) 789-5127 | jason.janoulis@altec.com

Cory Corcoran, Account Manager

(601) 850-4974 | cory.corcoran@altec.com

Jeff Stevens, Account Manager

(205) 914-5046 | jeff.stevens@altec.com

Primary Goods/Services:

Altec is a leading equipment and service provider for the electric utility, telecommunications, contractor, lights and signs, and tree care markets.

✦ **Asplundh Tree Expert, LLC**

P.O. Box 99 | Saginaw, AL 35137

2011 Hwy 87 | Alabaster, AL 35007

(205) 685-4000 | (205) 664-2165 (fax) | www.asplundh.com

Jacob Taylor, Manager

(205) 685-4000 | jtaylor@asplundh.com

Mark Johnson, Supervisor

(205) 685-4000 | mjohnson@asplundh.com

Primary Goods/Services:

Vegetation management, right-of-way line clearance and contracting tree removals.

⚡ **ATK Energy Group**

6909 Old Highway 441 #112 | Mount Dora, Florida 32757
401 South 16th Street, Clarinda, Iowa 51632
info@atkenergygroup.com | www.capeelectric.com

Dan Roser, Director of Client Solutions

(985) 502-2826 | *Daniel.roser@atkenergygroup.com*

Bill Chesney, Director of Client Solutions - Cooperatives

(850) 228-6096 | *William.chesney@atkenergygroup.com*

William Tate, Director of Client Solutions – Blue Sky

(513) 630-4775 | *wtate@atkenergygroup.com*

Primary Goods/Services:

At ATK Energy Group, we understand the demands of today's utility challenges — aging infrastructure, ever-stricter safety standards, tighter schedules, growing storm risks, and the need for more resilient power systems. We bring together seasoned professionals, national reach and integrated services to meet those challenges head-on. With us, you gain a partner who delivers from first design to final restoration — all under one roof.

⚡ **Beneficial Electrification League**

Keith Dennis, *kdennis@be-league.org*

3616 N. Glebe Road | Arlington, Virginia 22207

(571) 289-5615 | (571) 289-5615 (fax) | *www.be-league.org*

Primary Goods/Services:

The Beneficial Electrification League (BEL) was established in 2018 as a national 501(c)(3) nonprofit organization to unite a diverse coalition of organizations committed to making beneficial electrification a core strategy for addressing today's energy and economic challenges. Since then, BEL has emerged as a recognized national leader in rural electric technical assistance among small and mid-sized communities across the country. On behalf of rural electric cooperatives, municipal utilities, tribes, and local governments, BEL is in the process of helping implement billions of dollars of electric infrastructure investment that supports their unique electrification needs.

✦ **Better Safety and Training, LLC**

Jamie Camper, jamie@bettersafetytraining.com

P.O. Box 2368 | Albertville, AL 35950

(256) 960-4705 | www.bettersafetytraining.com | contact@bettersafetytraining.com

Primary Goods/Services:

Better Safety and Training, LLC enables individual companies and utilities to have a personal and customizable safety and training program to fit their specific needs. The goal is to create an atmosphere of safety-minded individuals who know, understand, and utilize their safety training for a safer workplace and better work environment as a whole.

✦ **Cahaba Energy Solutions, LLC**

Birmingham, AL 35242 | (205) 259-6469 | cahabaenergysolutions.com

Brandi Vines, President

(205) 585-0202 | bvines@cahabaenergysolutions.com

Luke Bright, Customer Relations Manager

(256) 339-6803 | lbright@cahabaenergysolutions.com

Primary Goods/Services:

Cahaba Energy Solutions is a women owned, employee-focused service company delivering valuable energy solutions through innovation and experience. We specialize in providing construction oversight, inspections for power crews and fiber crews, project management, estimating, and job closeouts. We also perform fiber design work using state of the art software to integrate physical fiber placement and splicing into one platform.

✦ **Cape Electrical Supply**

18944 N. Jefferson Street | Athens, AL 35614

(256) 353-0803 | (256) 353-7019 (fax) | www.capeelectric.com

Mike Morris, Vice President-Utility

(270) 353-0141 | m.morris@capeelectric.com

Mike Kennedy, Utility Sales Rep

(256) 353-0803 | m.kennedy@capeelectric.com

Konnor Kennedy, Utility Sales Rep

(256) 353-0803 | k.kennedy@capeelectric.com

Ryan Vangilder, Director of Procurement

(573) 837-8330 | r.vangilder@capeelectric.com

Primary Goods/Services:

Cape Electrical Supply is a full line utility distributor with a long tradition of serving utility customers within our market area. Municipals, Rural Electrical Co-Ops, and Investor-Owned utilities rely on Cape Electric's wide product offering and service capabilities allowing each to provide electrical power to their respective customers.

✈ **Central Service Association**

P.O. Box 3480 | Tupelo, MS 38803
93 S. Coley Rd. | Tupelo, MS 38801
(662) 842-5962 | (662) 840-1329 (fax) | www.csa1.com

Elissa Fulton, Relationship and Member Manager

(601) 842-0032 | efulton@csa1.com

Susan Griffin, Regional Account Manager

(662) 842-5962 (office) | (662) 542-6315 (cell) | sgriffin@csa1.com

Beth Harmon, Marketing Content Specialist

(662) 407-2721 (office) | (662) 665-1162 (cell) | bharmon@csa1.com

Primary Goods/Services:

Central Service Association provides a powerful integrated suite of solutions including customer information and financials, customer engagement & payment processing, engineering & operations, and productivity tool set. All designed to help your utility system run efficiently and effectively.

✈ **Corbitt Power & Light, LLC**

2795 AL Highway 205 S. | Albertville, AL 35950
P.O. Box 2368 | Albertville, AL 35950
(256) 660-0130 | (256) 660-0130 (fax) | www.corbittpower.com

Shannon Corbitt, President

(256) 660-0130 | shannon@corbittpower.com

Eddie Brown, Operations Superintendent

(256) 264-5232

Primary Goods/Services:

Corbitt Power & Light is a woman-owned company offering a complete range of overhead electric distribution construction services for new construction and emergency restoration and right-of-way clearing. Experienced line personnel and a fleet of well-maintained equipment reduces safety issues, improves productivity, and reduces down time. Corbitt Power & Light offers safe and quality service to meet your specific need.

✈ **Dragonfly Internet**

(877) 249-4647 | www.dragonfly.net

Butch Brock, Chief Strategy Officer

(334) 246-1146 | butch.brock@dragonfly.net

Royce Ard, Vice President, Sales and Marketing

royce.ard@dragonfly.net

Edward Taylor, Customer Experience Specialist

edward.taylor@dragonfly.net

Primary Goods/Services:

At Dragonfly, we believe better broadband starts with trust. We're committed to equipping previously underserved communities for the future with wireless and fiber infrastructure. Our residential and business customers alike benefit from locally based customer support and uncompromising service.

✈ **Electric Cities of Georgia (ECG)**

1470 Riveredge Pkwy. NW | Atlanta, GA 30328

(678) 213-6092 | www.ecoga.org

Jon Beasley, Vice President, Training & Safety

(770) 563-0328 | jbeasley@ecoga.org

James Adams, Georgia/Alabama Training & Safety Specialist

(706) 523-0925 | jamesadams@ecoga.org

Kelsey Bennett, Training & Safety Coordinator

(770) 820-6499 | kbennett@ecoga.org

Michelle Weekley, Manager, Member Training

(404) 272-0598 | mweekley@ecoga.org

Sabrina Milner, Director, Communications

(678) 213-6092 | smilner@ecoga.org

Primary Goods/Services:

The smart way to grow your utility employees with state-of-the-art training facilities and programs. Industry-leading training ensures linemen are prepared for real-world challenges and advancement.

✦ **Emerald Transformer**

4509 Hwy 83 N. | DeFuniak Springs, FL 32433

(800) 908-8800 | power@emeraldtransformer.com

Emily Church, Sales and Business Development

(706) 366-4190 | echurch@emeraldtransformer.com

Lee Megois, Sales Manager - Southeast

(205) 475-4700 | lmegois@emeraldtransformer.com

Primary Goods/Services:

With over fifty years of experience in the transformer services industry, Emerald Transformer is the premier solution for electrical equipment. Emerald provides a wide range of transformer services including remanufactured transformer stock, repairs, decommission, field technical services, parts, PCB disposal and recycling. Our national network of factories and service centers are strategically located to serve our broad and diverse customer base.

✦ **Fisher Arnold**

Standley Moore, Senior Vice President

9180 Crestwyn Hills Drive | Memphis, TN

(888) 583-9724 | smoore@fisberarnold.com | www.fisberarnold.com

Primary Goods/Services:

Fisher Arnold is a multi-disciplined firm of Engineers, Architects, Environmental Consultants, Land Planners, and Surveyors. Our electrical engineering services include Substation Design, Oil Containment, SCADA, Relay Settings & Coordination, Transmission Line Design, Distribution, Distributed Generation, System Studies, Arc Flash Analysis, Lockout/Tagout, System Planning, Mapping and GIS.

✈ **GRESKO**

1135 Rumble Road | Forsyth, GA 31029

(888) 766-0621 | www.gresco.com

Joey Arroyo, Sr. Vice President

(334) 673-9307 (office) | (334) 596-2776 (cell) | joey.arroyo@gresco.com

Jay Money, District Manager AL

(334) 673-9307 (office) | (334) 268-1352 (cell) | jay.money@gresco.com

Jason Champion, Vice President of Operations & Customer Service

(334) 673-9307 (office) | (334) 790-2617 (cell) | jason.champion@gresco.com

Chris Walker, Account Manager

(334) 673-9307 (office) | (334) 596-2779 (cell) | chris.walker@gresco.com

Norman Housch, Account Manager

(334) 673-9307 (office) | (615) 397-3563 (cell) | norman.housch@gresco.com

Joe Wolchina, Account Manager

(334) 791-7140 | joe.wolchina@gresco.com

Scott Sligh, Technical Representative

(251) 802-9043 | scott.sligh@gresco.com

Primary Goods/Services:

Specializes in stocking transformers up to 2500KVA, metering, lighting, tools, hardware, conductor and inventory management.

✈ **Hubbell Power Systems**

1615 Moores St. | Leeds, AL 35094

(205) 612-0900 | www.hubbellpowersystems.com

Kimberly Thomas, Territory Manager

(205) 612-0500 | kemthomas@hubbell.com

Walter Sinegal, Regional Director – Public Power SE

Primary Goods/Services:

Hubbell is focused on delivering high quality, dependable products. Internally, we are supported by our knowledgeable customer care teams. In the field, we work with our channel partners to deliver our product to market. Our network of distributors and retailers provide sales support, local inventory and expertise for the end-consumer. Together, they form a partnership with Hubbell that has played an important role in supporting our growth throughout our history.

✈ **Irby Utilities**

15350 Industrial Park Drive | Loxley, AL 36551

(850) 471-4936 | www.irbyutilities.com

Tressa Sinclair-Pierce, Branch Manager/Account Manager

(850) 377-4429 | sinclair@irby.com

Stewart McCart, Account Manager

(334) 618-7873 | mccart@irby.com

Brian Kriel, Account Manager

(334) 787-2700 | bkriel@irby.com

Jeff Miller, District Manager

(615) 319-4375 | jmiller@irby.com

Primary Goods/Services:

Irby is an electrical supply distributor providing total electrical solutions. Building profitable partnerships since 1926.

✈ **IUC – Interactive Utility Communications**

531 Roselane St NW, Suite 700 | Marietta, GA 30060

(844) 679-3714 | www.iucolutions.com

Greg Steele, CEO

(770) 639-3359 | gsteele@iucolutions.com

Primary Goods/Services:

Interactive Utility Communications was created to support the unique business requirements for the utility industry. Whether working with an investor-owned, municipality, or city government-run utility services, the service and focus of our organization is to provide solutions that are extensions of our clients' operations. Our clear understanding of the industries we support enables us to apply effective and flexible solutions to suit your organization's needs, regardless of size.

✦ **Jackson Line Clearing**

Andy McMillan, President

118 N. Royal Street, Suite #602 | Mobile, AL 36602

(251) 533-4312 | office@jack.sonlineclearing.com

Primary Goods/Services:

Jackson Line Clearing (JLC) provides electric cooperatives, municipalities, and utility companies with premium valued multi-state RIGHT OF WAY clearing services. Additionally, JLC provides herbicide spraying practices to minimize costs for right-of-way vegetation maintenance. We utilize modern technology and innovative practices, on the job, to expediently supply tree trimming service and right-of-way spraying to the highest expectation. JLC knows that the key to success is simple. Take pride in the services we offer, use the best equipment available, employ the highest quality labor, and take the proper precautions to ensure the safety and security of every employee.

✦ **Jackson Thornton CPAs & Consultants**

P.O. Box 96 | Montgomery, AL 36101

200 Commerce Street | Montgomery, AL 36104

(334) 834-7660 | (334) 956-5090 (fax) | www.jacksonthornton.com

Woody Trimble, Principal

(334) 261-6451 | woody.trimble@jacksonthornton.com

Jim Marshall, Principal

(334) 261-6483 | jim.marshall@jacksonthornton.com

Pat Cooper, Principal

(334) 240-3626 | pat.cooper@jacksonthornton.com

Erica Bailey, Principal

(334) 240-3627 | erica.bailey@jacksonthornton.com

Rich Compton, Principal

(334) 240-3684 | rich.compton@jacksonthornton.com

Primary Goods/Services:

Jackson Thornton Utilities provides audit, tax, and consulting services to more than 150 electric, gas and water providers, while maintaining the responsive, personalized attention that is the hallmark of our client-centered service. We consult with municipal utilities to design rates, create business strategy, enhance technology and provide training. From data requests and annual filings to testimony before regulatory boards, our clients count on us to provide them with multiple contacts for our management, consulting, and auditing expertise.

✦ **JJ Kane Auctions**

Dylan Evans

33 Inverness Center Parkway | Birmingham, AL 35242
(205) 936-1094 | www.jjkane.com | dylan.evans@jjkane.com

Primary Goods/Services:

JJ Kane Auctions is a division of Altec Industries in Birmingham, AL. We conduct weekly online auctions all over the United States. JJ Kane is the largest utility auction in the country. We work with many of the electric cities, investor-owned utilities, electric co-ops, and contractors.

✦ **JP Gaines Company**

2258 Brockett Road | Tucker, GA 30084 | (404) 444-2363

Patrick Martin, Operations Manager

(404) 444-2363 | pmartin@jpgainesco.com

Steve Minton, SE Regional Sales Manager

(470) 328-2439 | sminton@jpgainesco.com

Primary Goods/Services:

Tool provider for the utility industry. Also provide tool repair, electric, hydraulic, strap hoist, etc. Rubber track dealer.

✦ **Mayer Electric Supply, Inc.**

1390 Columbia Hwy | Dothan, AL 36301-1828

(334) 792-2111 | www.mayerelectric.com

Bryan Riddle, Outside Utility Sales

(334) 792-2111 | briddle@mayerelectric.com

Bruce Robinson, Branch Manager

(334) 792-2111 | brucerobinson@mayerelectric.com

Coty Taylor, Inside Utility Sales

(334) 702-3235 | coty.taylor@mayerelectric.com

Chad Daughtry, Inside Utility Sales

(334) 792-2111 | cdaughtry@mayerelectric.com

Primary Goods/Services:

Distributor of Electrical Supplies

✦ **Milwaukee Tool**

2875 Crescent Parkway, #1218 | Atlanta, GA 30339

(470) 717-2250 | www.milwaukeetool.com

Parker Thelen, Territory Manager

(470) 717-2250 | parker.thelen@milwaukeetool.com

Emmanuel Propst, Power Utility Key Account Manager

(407) 340-5660 | Emmanuel.propst@milwaukeetool.com

Primary Goods/Services:

Milwaukee Tool is a full solution provider focused on creating a safer, more efficient jobsite.

✦ **NexGen Utility Sales**

Patti Shaver, Territory Sales Manager

306B Gristmill Road | Forest, VA 24551 (physical address)

235 Ridge Point Ct. | Alpharetta, GA 30022 (mailing address)

(434) 386-1688 | www.nexgenutilitysales.com | pshaver@nexgenreps.com

Primary Goods/Services:

NexGen Utility Sales is a woman-owned manufacturer's representative firm dedicated to serving the utility industry. We specialize in connecting our customers with custom-engineered solutions tailored to meet their unique needs. With a highly skilled and experienced team, we are committed to delivering exceptional service, technical expertise, and reliable support. Backed by over 200 years of combined experience in sales, customer service, technical support, and marketing, our mission is to ensure your success through innovative, dependable solutions and strong, lasting relationships.

✦ **NISC (National Information Solutions Cooperative)**

One Innovation Circle | Lake St. Louis, MO 63367

(866) 999-6472 | (701) 667-1936 (fax) | www.nisc.coop

Linda Richardson, Manager Business Development & Sales

(866) 999-6472 | (724) 413-9373 (cell) | linda.richardson@nisc.coop

Monica McGeorge, Lead Industry Consultant

(866) 999-6472 | (865) 456-5015 (cell) | monica.mcgeorge@nisc.coop

Keith Jones, Sales Manager

(866) 999-6472 | (919) 349-2408 (cell) | keith.jones@nisc.coop

Tom Davis, Account Manager

(866) 999-6472 | (432) 342-8383 (cell) | tom.davis@nisc.coop

Primary Goods/Services:

NISC delivers advanced IT solutions, services and support to more than 950 electric cooperatives, independent broadband companies and public power entities. NISC's integrated enterprise solutions include financials, service, operations, marketing and additional other supporting platforms and business services.

✦ **NTS, Inc.**

Matt Bailey, Regional Sales Manager

1887 Highway 36 | Chelsea, AL 35043 | (601) 594-5656

www.ntsontweb.com | m Bailey@nationaltransformer.com

Primary Goods/Services:

NTS, Inc. is a manufacturers representative located in Raleigh, NC that has been serving electric utilities in North Carolina, South Carolina, Virginia, Maryland, Delaware, Alabama, Georgia and the Florida Panhandle since 1984. NTS has grown to become the premier manufacturers' representative of equipment, materials, and services in the electric utility industry, serving more than 20 lines. Our sales team is committed to providing our customers the best service in the industry. Service is our business, and NTS takes pride in everything we do for our customers and suppliers.

✦ **Osmose Utilities Services, Inc.**

635 Hwy. 74 South | Peachtree City, GA 30269

(770) 631-6995 | www.osmose.com

Shane Heartsill, Director of Business Development

(770) 631-6995 (office) | (901) 494-2129 (cell) | sheartsill@osmose.com

Chad Thorne, Director of Business Development

(602) 703-9515 | chadthorne@osmose.com

Primary Goods/Services:

Osmose provides professional inspection, life extension, and rehabilitation services designed to build resiliency into utility structures. With more than 80 years of experience, Osmose proudly serves America's utilities as they manage aging infrastructure and build tomorrow's intelligent utility.

✦ **Preferred Sales Agency**

Landon Andrews, Territory Manager

(205) 534-6764 | www.preferred-sales.com | landrews@preferred-sales.com

Primary Goods/Services:

Our mission is to provide quality professional services, innovative solutions, and growth opportunities for all those that depend upon us, including our manufacturers, our customers, our employees, and our community. We are committed to excellence, and we will accomplish our objectives by stressing honesty, integrity, and diligence, remembering that we exist to serve others.

✦ **Royal Engineers and Consultants, LLC**

1501 Religious Street | New Orleans, LA 70130

(504) 283-9400 | royal.us

Michael Pugh, President | mpugh@royal.us

Henry Albert, Executive Vice President | halbert@royal.us

Kristie Lancon, Senior Vice President, Disaster Recovery |

klancon@royal.us

Mac McNeil, Senior Vice President | (251) 605-0199 | mmcneil@royal.us

Primary Goods/Services:

Royal Engineers and Consultants is an engineering and consulting firm specializing in Civil Engineering, Disaster Recovery Services, FEMA Public Assistance, Coastal Services, Construction Management and Project Management.

✦ **Sensus**

Toby Smith, Director of Sales – North American Energy
266 Boinest Road | Prosperity, SC 29127
(803) 271-6550 | www.sensus.com | toby.smith@xylem.com

Primary Goods/Services:

Sensus, a Xylem brand, provides remotely-managed products and solutions that deliver the right data at the right time for investor-owned utilities, cooperatives and municipalities. As part of Xylem’s digital portfolio, our smart devices and advanced applications connect with a variety of communication technologies to help customers make timely decisions that optimize electric, gas and water systems.

✦ **Service Electric Company**

1631 East 25th Street | Chattanooga, TN 37404
(423) 265-3161 | www.serviceelectricco.com

Chris Froehlich, President

W. Scott Smith, Regional VP

Joe Bell, Regional Manager – Distribution

Pete Bartlett, Director of Operations

Primary Goods/Services:

Service Electric is a construction firm equipped to build, maintain, and repair the infrastructure that powers the nation. Our services include the construction and maintenance of Transmission and Distribution Lines, Substations, Network Underground and URD, Technical Services, Energized Services, and Emergency Storm Restoration. Service Electric brings a serious commitment to safety, exceptional crews, specialized equipment, and vast industry experience to every job site. We’re equipped to tackle any electric power construction project up to 765kV. What sets us apart is SERVICE. Serving client needs is our mission. Meeting the timeline. Working within budgets. Implementing an innovative solution. It’s all part of our approach. SERVICE is not just our name. It’s how we do business.

✦ **South Source Sales**

1809 Riverchase Drive, Suite 36009 | Hoover, AL 35244

(205) 612-2151 | www.southsourcesales.com

James Raco, President

(205) 612-2151 | james@southsourcesales.com

Brian Kriel, P.E., Territory Manager

(334) 787-2700 | kriel@southsourcesales.com

Primary Goods/Services:

South Source Sales is a female-owned manufacturer's representative and distributor serving the electric utility and commercial/industrial markets in the states of Alabama, Tennessee, Georgia, Mississippi, Louisiana, Arkansas, and the Florida panhandle. We are an organization that believes in values, integrity, trust, honor, and dignity.

✦ **Stewart Engineering, Inc.**

Lance Junkin, President

P.O. Box 2233 | Anniston, AL 36202

300 East 7th Street | Anniston, AL 36207

(256) 237-0891 | lance@stewartengineering.org

Primary Goods/Services:

We are electrical engineers providing consulting services to municipal electrical systems throughout the state of Alabama.

✦ **Sumter Utilities, Inc.**

1151 N. Pike W. | Sumter, SC 29153

P.O. Box 579 | Sumter, SC 29151

(803) 469-8585 | (803) 469-4600 (fax) | www.sumter-utilities.com

Derek O'Bradovich, President

Ben Stegner, VP of Operations

Mark Martines, VP of Operations

John Burton, Safety Director

Derek Lee, Director of Operations

Primary Goods/Services:

For more than 90 years, Sumter Utilities, Inc. has served as the power contractor of choice for investor-owned utilities, electric cooperatives, and municipalities. We deliver high-quality electrical construction services, products and total electrical systems integration, including construction, maintenance and modification of Transmission Lines (69 kV and above) – Overhead; Distribution Lines (up to 34.5 kV) - Overhead & Underground; Substations; Solar Power Cell Fields.

✦ **Sunbelt Solomon**

P.O. Box 1009 | 201 Polymer Drive | Decatur, TN 37322
(888) 949-2666 | (423) 334-2662 (fax) | www.sunbeltsolomon.com

Daresa Denis, Account Manager

(888) 949-2666 (o) | (423) 453-0420 (c) daresa.denis@sunbeltsolomon.com

David Delee, Business Development Manager

(706) 585-0554 | david.delee@sunbeltsolomon.com

Primary Goods/Services:

Sunbelt Solomon is one of the world's largest solution providers of electrical equipment, backed up by 50 years of experience. We offer an unmatched ability to package equipment and services, providing our customers with complete turn-key solutions. Our reach is nationwide. Our service is personal. When you're a customer, no piece of equipment is more important than yours. Whether it's a custom-designed transformer, a rental component, or a totally tailored, complete solution. We are committed to providing industry-leading service to our utility, industrial, and commercial customers. Our engineering support, safety, and environmental records and dedication to delivering quality products have set us apart from the competition. We are here for you 24 hours a day, 7 days a week, 365 days a year.

✦ **Swift Industrial Power**

Nathan Jones, Territory Manager

10917 McBride Lane | Knoxville, TN 37932

(205) 616-1226 | www.swiftpower.com | njones@swiftpower.com

Primary Goods/Services:

Swift Power offers batteries and chargers for the growing needs of utility applications, including switchgear and control, power generation, renewable energy as well as DC power for fiber and broadband applications.

✈ **Tallman Equipment Company, Inc.**

6440 South International Drive | Columbus, IN 47201

(877) 860-5666 | www.tallmanequipment.com

Chris Long, Tool Specialist

(205) 753-3896 | chrisl@tallmanequipment.com

John Downey, Marketing Director

(877) 860-5666 | jobnd@tallmanequipment.com

Primary Goods/Services:

Founded in 1952, Tallman Equipment Company supplies specialized tools, equipment, and services to the electric utility industry. We support lineworkers and utility operations with a comprehensive range of products, including line stringing equipment, lifting and rigging solutions, fiberglass tools, rubber goods and cover-up, and grounding and jumper assemblies. Our focus is on safety, reliability, and efficiency, ensuring utilities and their crews have the resources they need to perform critical work. Tallman is recognized as a trusted partner across the industry, providing both equipment and expertise to help utilities meet the demands of their field operations.

✈ **Taylor Electric, Inc.**

5592 Wall Triana Highway | Madison, AL 35758

(256) 724-1447 | (256) 895-0731 (fax) | www.taylorelectricutility.com

Todd Taylor

(256) 724-1447 | todd@taylorelectricutility.com

Chris Holladay

(256) 527-4401 | chris@taylorelectricutility.com

Primary Goods/Services:

Since 1972 Taylor Electric has specialized in overhead and underground distribution construction and maintenance, substation and transmission line construction, commercial and Industrial maintenance, storm restoration, fiber optic construction, outdoor lighting and GIS mapping services.

✦ **Tennessee Valley Public Power Association (TVPPA)**

Caleb Hall, Director, Education and Training

1206 Broad St., Suite 104 | Chattanooga, TN

(423) 883-5000 | www.tvppa.com | chall@tvppa.com

Primary Goods/Services:

The Tennessee Valley Public Power Association, Inc. (TVPPA) is the nonprofit, regional service organization that represents the interests of consumer-owned electric utilities operating within the Tennessee Valley Authority (TVA) service area. TVPPA members include both municipal and electric cooperatives, and they serve more than 10 million people in Alabama, Georgia, Tennessee, Mississippi, Kentucky, North Carolina and Virginia.

✦ **Terex Utilities**

1135 13th Avenue NE | Watertown, SD 57201

(605) 882-4000 | www.terex.com/utilities

Nancy Hulscher, Marketing Coordinator

(605) 882-5526 | nancy.hulscher@terex.com

Griffin Pertanka, Account Manager

(334) 201-2127 | griffin.petranka@terex.com

Primary Goods/Services:

Terex Utilities, Watertown, S.D. – Terex Utilities is a leading provider of digger derricks, aerial devices and auger tooling to the electric utility, tree care and electric construction industries. We are an industry leader in the design and manufacture of this equipment used in the United States and around the world. Learn more about them at www.terex.com/utilities.

✦ **The Okonite Company**

Don Ryan, District Manager

8088 US Highway 11, Suite 101 | Springville, AL 35146

(205) 568-3958 | www.okonite.com | d.ryan@okonite.com

Primary Goods/Services:

Premier manufactures of high quality insulated electrical wire and cable since 1878.

✦ **Thompson Engineering**

2970 Cottage Hill Road, Suite 190 | Mobile, AL 36606

(251) 666-2443 | www.thompsonengineering.com

Chris Dugger, Vice President

(251) 747-0716 | cdugger@thompsonengineering.com

Eliska Morgan, Government Relations/Business Development Manager

(251) 665-5429 | emorgan@thompsonengineering.com

Primary Goods/Services:

Thompson Engineering specializes in providing comprehensive surveying services tailored to meet the specific needs of clients in various industries. Their expertise extends to precise land surveying, utilizing advanced technologies like LiDAR and GPS to generate highly accurate data crucial for infrastructure development, urban planning, and environmental assessment. In the context of the power and local energy market, Thompson Engineering's surveying capabilities play a pivotal role in optimizing site selection for renewable energy projects, facilitating efficient transmission line routing, and ensuring compliance with regulatory requirements. By delivering detailed topographic surveys and comprehensive mapping solutions, they enable stakeholders to make informed decisions, enhance operational efficiency, and minimize environmental impact, thus contributing to the sustainable growth of the energy sector.

✈ **TRC Companies, Inc.**

4155 Shackleford Blvd., Suite 225 | Norcross, GA 30093
(770) 270-1192 | www.trccompanies.com

Joel Mullinax, Vice President of Distribution Operations

(404) 202-9445 | jmullinax@trccompanies.com

Bobby Payne, Distribution Operations Director

(678) 296-5779 | bpayne@trccompanies.com

David McCullough, Support Services Manager

(770) 550-3804 | dmcullough@trccompanies.com

Titus Diamond, Contract Consultant

(470) 585-3330 | tdiamond@trccompanies.com

Primary Goods/Services:

Distribution Design Services, Joint Use Management, Storm Restoration Services, Energy Services, GIS.

✈ **Utility Specialists, Inc.**

P.O. Box 43528 | 3908 Cypress Drive | Birmingham, AL 35243
(205) 967-4602 | www.utility-specialists.com

Joe Thornton, Account Manager

(800) 733-4837 (office) | (205) 243-6911 (cell) | joe@utility-specialists.com

Primary Goods/Services:

Provides equipment for power delivery, metering, substation and generation for electric power companies. Serving the electric power industry since 1957.

✈ **Volkert, Inc.**

P.O. Box 7434 | Mobile, AL 36670
11 North Water Street, RSA Tower 18th Floor | Mobile, AL 36602
(251) 342-1070 | www.volkert.com

Leon Barkan, President and COO

(251) 342-1070 | leon.barkan@volkert.com

George Talbot, Senior Vice President External Affairs

(251) 342-1070 | george.talbot@volkert.com

“Hank” Harold Eubanks, Regional Vice President

(251) 342-1070 | harold.eubanks@volkert.com

Chad Hood, Program Manager

(251) 342-1070 | chad.hood@volkert.com

Primary Goods/Services:

Volkert, Inc. is an employee-owned professional services firm focused on delivering the future of infrastructure for state and federal agencies, local and municipal governments, and private industry. Founded in 1925, Volkert has grown from a regional to a full-service firm with a nationwide client base. As one of the largest engineering firms based in Alabama, Volkert has completed hundreds of major projects across the state and consistently ranks among the nation’s top 100 design (ranked annually by Engineering News-Record).

✈ **Wesco**

225 West Station Square Drive, Suite 700 | Pittsburgh, PA 15219
(256) 656-8127 | www.wesco.com

Daniel Agee, Director, Utility Sales

(678) 216-9467 | daniel.agee@westcodist.com

Mickey Wallace, Utility Sales Representative

(256) 656-8127 | thwallace@westcodist.com

Jake West, Southeast Business Development Manager FTTX

(931) 627-3711 | jwest@westcodist.com

Tim Royster, Senior Specialist – Technical Sales

(770) 216-9467 | timothy.royster@anixter.com

Kathy Thomas, Sr. Marketing Specialist, Utility

kathy.thomas@westcodist.com

Primary Goods/Services:

As a world leader in electrical, communications and utility distribution, and supply chain services, we’re ready and able to help you navigate business complexities.

✦ **Whitehead & Associates, Inc.**

438 Carr Avenue, Suite 5 | Birmingham, AL 35209

(404) 843-1815 | www.whiteheadassoc.com

Peyton Whitehead, Sales | (404) 316-0920 | peyton@whiteheadassoc.com

John Shelfer, Sales | (205) 612-7904 | john@whiteheadassoc.com

Ben Garrett, Sales | (205) 767-7629 | Ben@whiteheadassoc.com

Jim Farrar, Sales | (205) 218-3432 | jim@whiteheadassoc.com

Hammond Parsons, Sales

(334) 544-9054 | hammond@whiteheadassoc.com

Primary Goods/Services:

Whitehead & Associates represents leading manufacturers in the electric utility industry. Our comprehensive range of products and services covers the entire spectrum of electrical needs, with a particular focus on transmission and distribution infrastructure. From power transformers to pole line hardware, our expertise encompasses a wide variety of products and solutions to meet the specific requirements of our clients within the electric utility industry.

HUBBELL®

Power Systems, Inc.



DISTRIBUTION



SUBSTATION



TRANSMISSION



COMMUNICATION

Kimberly Thomas, Territory Manager
Hubbell Power Systems
205-612-0500
kmthomas@hubbell.com





ELECTRIC CITIES
OF ALABAMA

**ALABAMA RURAL
ELECTRIC
ASSOCIATION**

Alabama Rural Electric Association

Arab Electric Cooperative

Stacey White, General Manager
P.O. Box 770 | Arab, AL 35016
stacey@arab-electric.org
256-586-3196

Baldwin EMC

Hunter Robinson, CEO
P.O. Box 220 | Summerdale, AL 36580
hrobinson@baldwinemc.com
251-989-6247

Black Warrior EMC

Daryl Jones, General Manager
P. O. Box 779 | Demopolis, AL 36732
daryljones@blackwarrioremc.com
334-289-0845

Central Alabama Electric Cooperative

Tom Stackhouse, President/CEO
103 Jesse Samuel Hunt Blvd | Prattville, AL 36066
tmstackhouse@coop.caec.com
334-365-6762

Cherokee Electric Cooperative

Randal Wilkie, CEO/Manager
P.O. Drawer O | Centre, AL 35960
randal.wilkie@cherokee.coop
256-927-5524

Clarke-Washington EMC

Steve Sheffield, General Manager
P.O. Box 398 | Jackson, AL 36545
s.sheffield@cwemc.com
251-246-9081

Coosa Valley Electric Cooperative

Jon Cullimore
P.O. Box 837 | Talladega, AL 35161
ljcullimore@coosavalleyec.com
256-362-4180

Covington Electric Cooperative

Mark Parker, CEO and General Manager
18836 U. S. Highway 84 | Andalusia, AL 36421
mparker@covington.coop
334-222-4121

Cullman Electric Cooperative

Tim Culpepper, General Manager
P.O. Box 1168 | Cullman, AL 35056
timc@cullmanec.com
256-737-3200

Dixie Electric Cooperative

Gary Harrison, President and CEO
9100 Atlanta Highway | Montgomery, AL 36117
gary.harrison@dixie.coop
334-288-1163

Franklin Electric Cooperative

Mark Stockton, General Manager
P.O. Box 10 | Russellville, AL 35653
smalone@fecoop.com
256-332-2730

Joe Wheeler EMC

Gene Kanikovsky, General Manager
P.O. Box 460 | Trinity, AL 35673
gkanikovsky@jwemc.org
256-552-2300

Marshall-DeKalb Electric Cooperative

Scott Bobo, General Manager
P.O. Box 724 | Boaz, AL 35957
sbobo@mdec.org
256-593-4262

North Alabama Electric Cooperative

Gene Hall, General Manager
P.O. Box 628 | Stevenson, AL 35772
ghalk@naecoop.com
256-437-2281

Pea River Electric Cooperative

Jeff Hodges, General Manager
P.O. Box 969 | Ozark, AL 36361
jeff.hodges@peariver.com
334-774-2545

Pioneer Electric Cooperative

Terry Moseley, General Manager
P.O. Box 468 | Greenville, AL 36037
tmoseley@pioneerelectric.com
334-382-6636

Sand Mountain Electric Cooperative

Joseph Bates, General Manager
P.O. Box 277 | Rainsville, AL 35986
smec@smec.coop
256-638-2153

South Alabama Electric Cooperative

David Bailey, General Manager
P.O. Box 449 | Troy, AL 36081
davidb@southaec.com
334-566-2060

Southern Pine Electric Cooperative

Vince Johnson, President and CEO
P.O. Box 528 | Brewton, AL 36427
vjohnson@southernpine.org
251-867-5415

Tallapoosa River Electric Cooperative

Louie Ward, General Manager
P.O. Box 675 | LaFayette, AL 36862
lward@trec.coop
334-864-9331

Tombigbee Electric Cooperative

Britton Lightsey, CEO
3196 County Highway 55 | Hamilton, AL 35570
blightsey@tombigbee.org
205-921-6712

Wiregrass Electric Cooperative

Brad Kimbro
P.O. Box 158 | Hartford, AL 36344
bkimbro@wiregrass.coop
334-588-2223

Serving Alabama Electric Cities and Rural Cooperatives

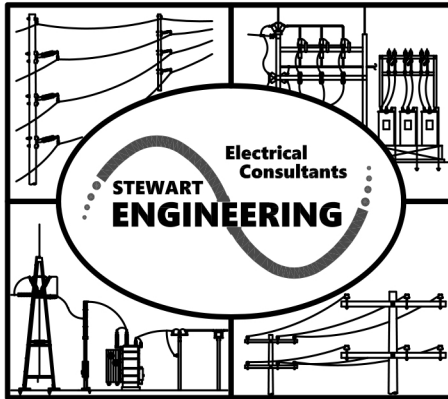

STEWART ENGINEERING, INC.

Electrical Consultants

300 East 7th Street (36207)

PO Box 2233 (36202)

Anniston, Alabama

Telephone: (256) 237-0891

Email: services@stewartengineering.org

Over 140 Years of Combined Operating Experience

Distribution Design (Overhead & Underground)

Transmission Design

Substation Design

Construction Work Plans

Long Range Engineering Plans

Work Order Inspections

System and Sectionalizing Studies

Arc Flash Analysis

Rate Studies

Mapping

Staking

Relay Testing

Osmose®

Resilient Grids. Strong Networks. Safe Energy.



Wood



Joint
Use



Underground
Vault



Underground
Cable



Products



Steel



Technical



Aerial



Contact
Voltage



Storm

Leveraging 90 years of expertise to make the grid as strong, safe, and resilient as the communities it serves.

Contact your local Osmose professional to learn more:

Shane Heartsill
sheartsill@osmose.com
901.494.2129



Or, visit us at osmose.com.



Preferred Sales Agency, LTD.
Manufacturers' Representatives

We proudly represent the following lines in Alabama:



Midal Cables



Contact us for more information:

Landon Andrews

Territory Manager
(205) 534 6764
landrews@preferred-sales.com

Collin Jolly

Territory Manager
(205) 799-0288
cjolly@preferred-sales.com

Grant Rogers

Territory Manager
(251) 689-9152
gjones@preferred-sales.com

Jessica Shue

Customer Service Rep
(704) 439-2126
jshue@preferred-sales.com

To see more about our lines, please visit: www.preferred-sales.com



ELECTRIC CITIES OF ALABAMA

UNITING ALABAMA'S ELECTRIC CITIES



Energy Savings Through Prepayment



As your public power utility grows, so does its need for low-cost energy. Energy Southeast, A Cooperative District®, is ready to help by significantly reducing your power supply cost. If your utility is looking for innovative ways to reduce expenses, we have the resources and expertise to make it happen.

Prepaid Electricity: Prepay Bonds Generate Savings

Energy Southeast, A Cooperative District, has developed partnerships to save money on existing power supply for municipal utilities. These prepay projects:

- ⚡ Produce millions of dollars in energy savings each year
- ⚡ Fully utilize your utility's tax exempt status
- ⚡ Do not impact utility operations and require few administrative changes
- ⚡ Do not impact existing power supply arrangements
- ⚡ Maintain total flexibility in your future energy procurement
- ⚡ Simplify financing by using Energy Southeast, A Cooperative District, as a conduit
- ⚡ Do not impact your utility's credit metrics or borrowing limits

With a prepay project, Energy Southeast, A Cooperative District, can save money on existing power supply contracts and future energy needs all without changing your utility's financial profile.

Prepaid Energy Program

Energy Southeast, A Cooperative District, issues tax-exempt municipal bonds to prepay for future energy that will be sold to your utility, saving you money. You'll experience a significant reduction in power costs, providing for long-term financial stability and security.

Value We Bring to Our Clients

\$145
MILLION
Energy Savings

\$3.4
BILLION
Prepay Bonds Issued



Make your energy project a reality with funding through Energy Southeast, A Cooperative District. Call 334.262.1126 or visit energysoutheast.org.



EMPOWERING Quality of Place

Why Public Power Matters

Public power invests in quality of life: **strong schools, active recreation, a robust economy**, access to **top-tier healthcare**, and **opportunities to grow**. Energy Southeast (formerly the Alabama Municipal Electric Authority) does more than provide electricity—it builds thriving futures for Member communities.



Public Power's Bright Future

Energy Southeast is leading the way in public, locally-owned power, expanding to deliver new, innovative energy solutions. We're equipped to help our members grow sustainably and achieve true quality of place. For energy leadership in the 21st century, look no further than Energy Southeast.



energysoutheast.com